

## Explosion Tested Drum Kit

### APPLICATIONS

The NFPA compliant Raptor Drum™ Explosion Tested Drum Kit acts as an extension of the dust collector. It is an innovative solution for explosion isolation. No need for wiring, maintenance, motor, starter, wipers, chains.



### STANDARD FEATURES

- Standard sizes : 10" -18", 55 gallon or 20 gallon drum

### SIMPLE AND PROVEN

- Explosion Tested to 7psi
- NFPA 69/654 Compliant
- Bonded to a Grounded Collector
- No Moving Parts
- No Flex Hose
- Tool Free
- Tested Up to 185kscf



PRODUCT CODE : 51301

## DIMENSIONS

PRODUCT CODE SIZE	DIAMETER	DESCRIPTION
5910010	10"	Raptor Drum Kit 55 Gallon or 20 Gallon Drum
5910012	12"	Raptor Drum Kit 55 Gallon or 20 Gallon Drum
5910014	14"	Raptor Drum Kit 55 Gallon or 20 Gallon Drum
5910016	16"	Raptor Drum Kit 55 Gallon or 20 Gallon Drum
5910018	18"	Raptor Drum Kit 55 Gallon or 20 Gallon Drum

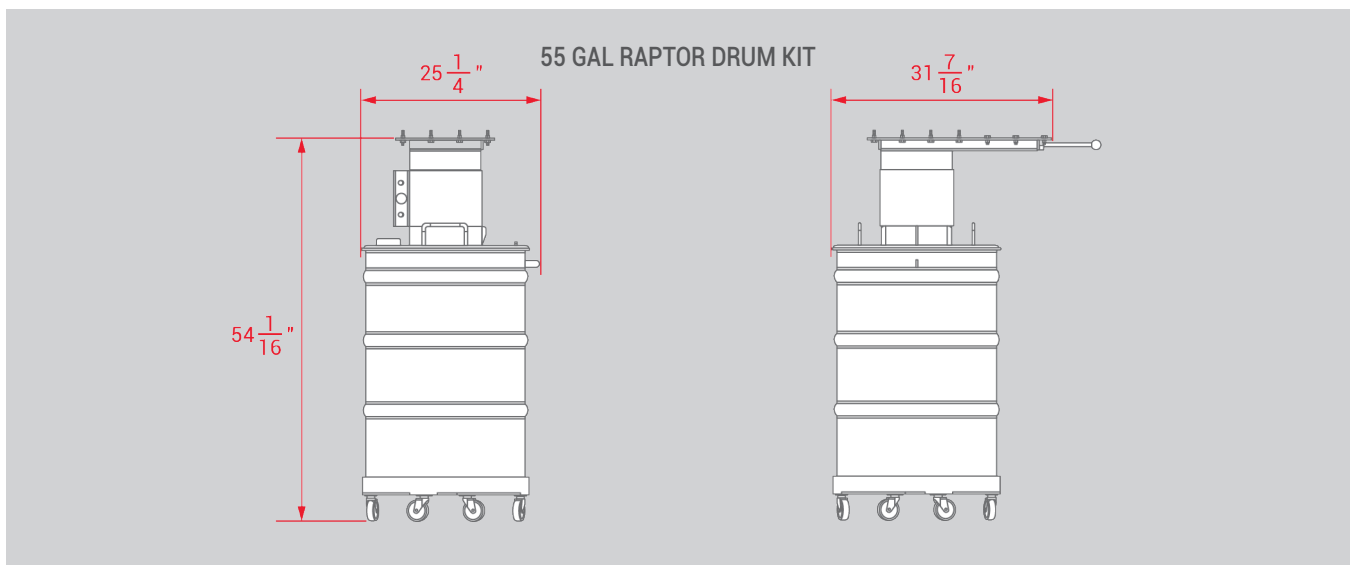

## HOW RAPTOR DRUM WORKS

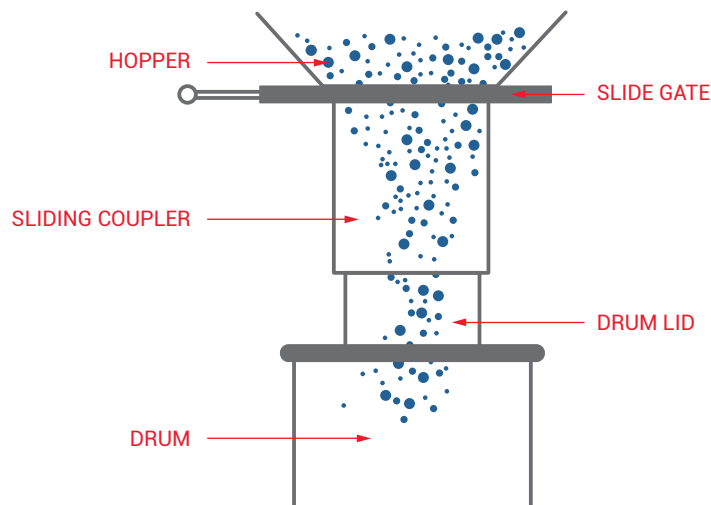

© August 2023 Boss Products, LLC