

## USE

- The CDS80C VIGIBELT® is an elevator belt alignment system which has to be placed on an elevator in order to avoid any friction between the belt and the inner sides of the elevator's leg. The CDS80C VIGIBELT® has to be installed by pair on the going-up leg, above the elevator's foot. As far as elevators higher than 20 meters are concerned, the head also has to be equipped on the up-going leg.
- One or several targets also have to be installed on the elevator's belt (at about every 30 meters) to enable an even more accurate control.

## DESCRIPTION

- CDS80C VIGIBELT® is composed of two sensors, one setting element, one metal sheet of back plane and of bolts.

### Possible adjustment for the VIGIBELT® CDS80C

- The CDS80C elevator belt alignment is meant to be pre-set for control ranges from 15/20/25/30/36 mm between the inner side of the elevator's shaft and the target ( please refer to the orange setting element). The control range of 10 mm is meant for the VIGIBELT® CDS80CS only (one more plate 5 mm thick).

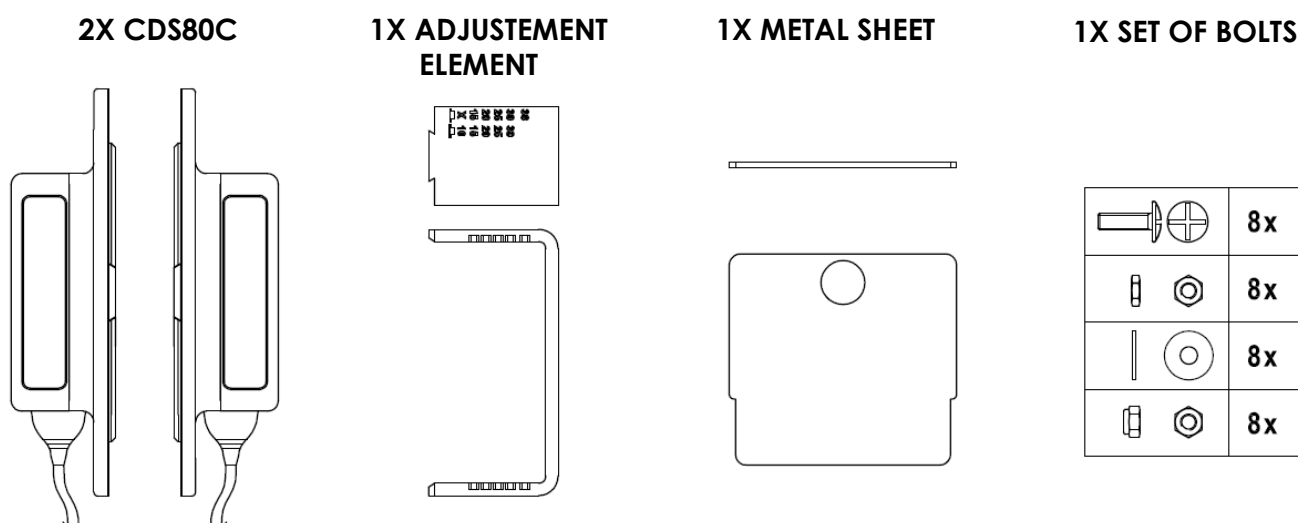

## SAFETY INSTRUCTIONS

- VIGIBELT® CDS80C has to be assembled, connected and brought into service only by qualified staff. The staff must know the classes of protection, the legislation in industrial area, especially in ATEX area .
- First of all, calculate the maximum authorised misalignment between the target and the inside of the elevator permitted.
- Before bringing into service or before any intervention of the VIGIBELT®, the elevator must be stopped.
- The user is in charge of the throwing out of the CDSC80. Its components according their nature (polycarbonate, EPDM rubber, steel, etc) have to be discarded in the corresponding sorting centres.

**INSTALLATION**

- According the Diagram A, make two symmetrical openings on each side of the up shaft (square opening of 112 mm + 4 holes Ø6.5 on a square of 126).
- Put together the M6 screws with the low nuts on the shaft (tightening torque of 6 N.m).
- According the electrical Diagram C, please connect the CDS80CS.
- After having preset the system, put it in place.
- Following the Diagram B, screw the M6 locking nuts together with the L washers (tightening torque of 4 N.m).

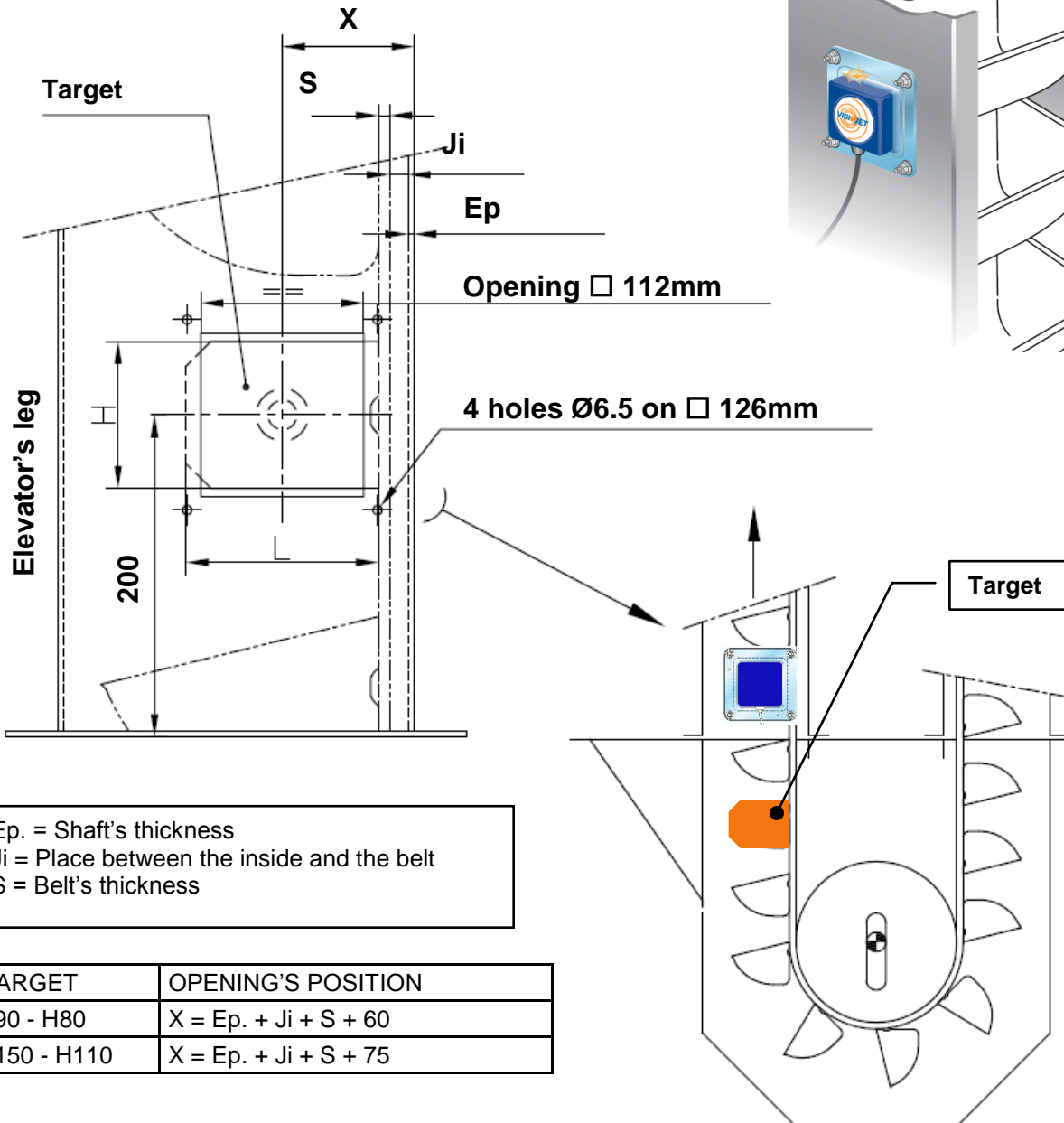

**Caution : obligation to install a target bucket every 30 meters of belt for elevator with plastic or stainless steel bucket.**

**Diagram A**

Ep = Shaft's thickness  
 Ji = Place between the inside and the belt  
 S = Belt's thickness

TARGET	OPENING'S POSITION
L90 - H80	$X = Ep. + Ji + S + 60$
L150 - H110	$X = Ep. + Ji + S + 75$

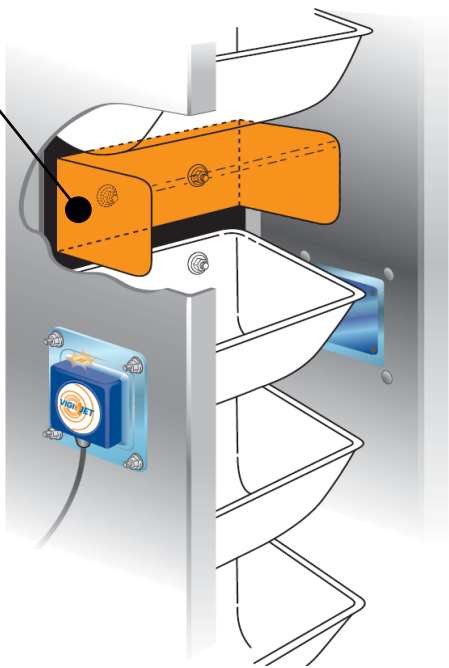

**INSTALLATION**

**Diagram B**

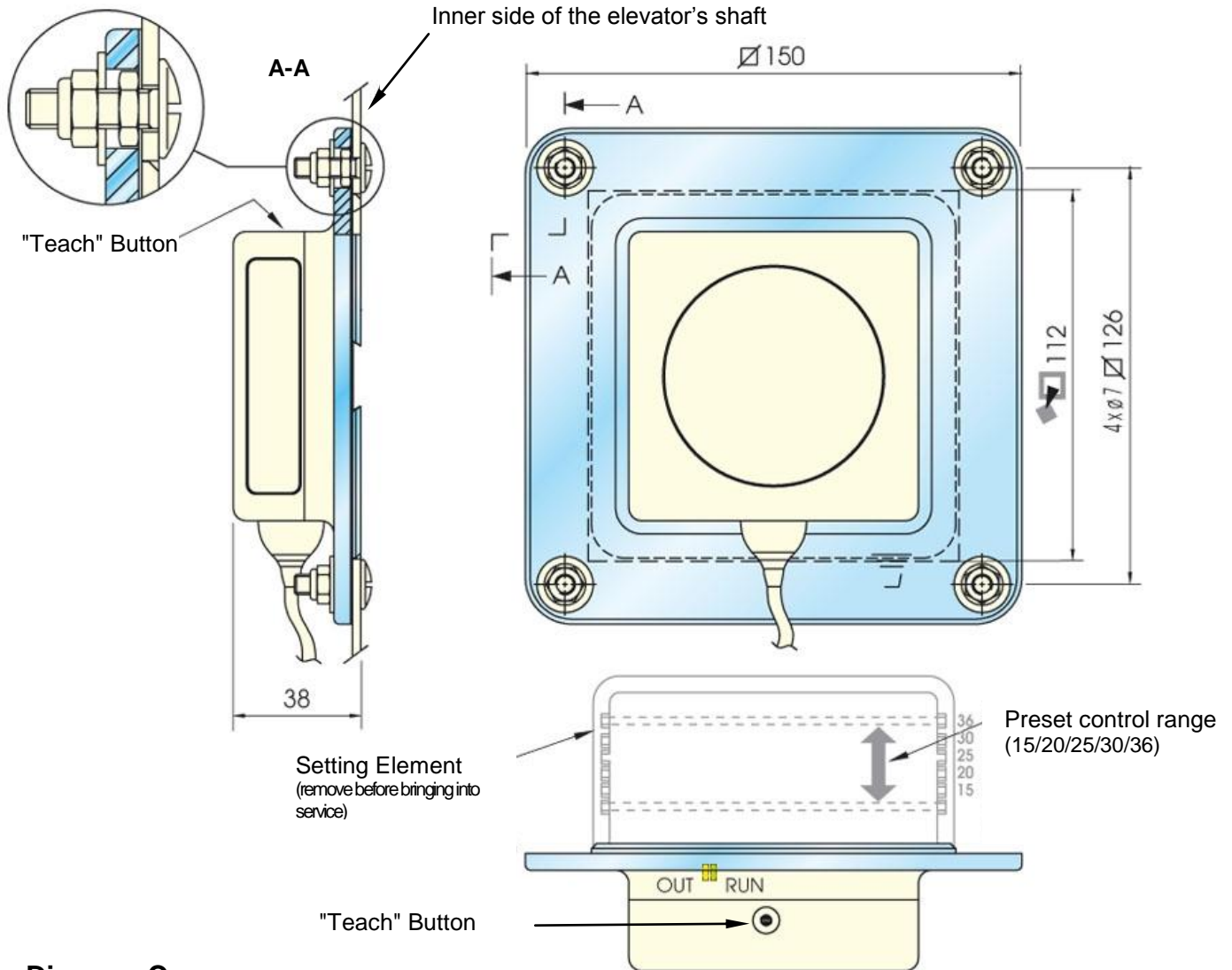

**Diagram C**

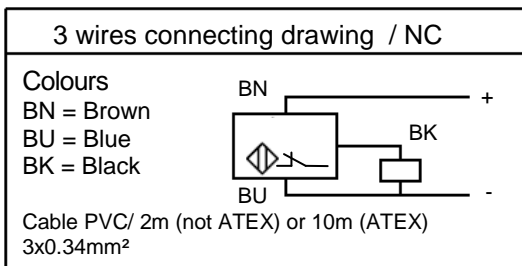

**For DC voltage sensor, ATEX or not**

- Connecting through a 3 wire cable
- Cable length L=2m (not ATEX) or L=10m (ATEX  $\text{Ex}$ )
- Supplying voltage - 12...24V DC
- Voltage's limits (including undulation) - 10...38V DC
- Protection - IP67



Be careful electrical connecting must be made out of the ATEX ZONE  $\text{Ex}$

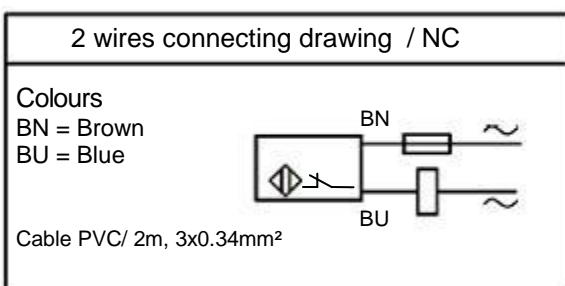

**For AC/DC voltage sensor, ATEX not available**

- Connecting through a 2 wire cable
- Cable length L=2m
- Supplying voltage - 24...240V AC/DC
- Voltage's limits (including undulation) - 20...264V AC/DC
- Residual voltage at nominal I  $\leq 5.5V$
- Protection - IP68



The load must be twinned with a fuse of 0.4A

**PRESET**
**1) TEACHING OF THE ENVIRONMENT :**

With back ground metal parts like an elevator's shaft, it is necessary for the environment to be taught by placing the VIGIBELT® on the opening (please refer to the D drawing) without any setting element.

- With a pin, press and keep pressed the button. The green led will first switch off, then, 3 seconds later, when it is on again,
- release the button.
- The green led will flash three times to indicate that the detector is being recognising its environment. There are two possibilities :
  - **Either, the green led remains on** which means that the detector did recognise its environment and is ready to run. Any subject in its detection field will be detected
  - **Or, the green led flashes very quickly** which means that the teaching failed.  
i.e. there are too many big metallic items nearby the monitor. In that case, the installation conditions have to be reviewed and a reset has to be made (please see below).

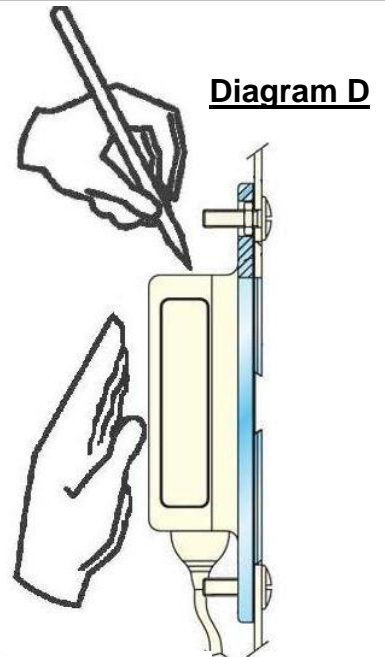
**2) DISTANCE TEACHING OF THE ITEM TO BE DETECTED :**
**DO NOT CUT THE SUPPLY BETWEEN THE STEP 1) AND 2)**

- Remove the CDS80C off the leg, put the adjustment element (orange) on the CDS80C,
- Put the back ground metal sheet on the setting element into the rack corresponding to the chosen control distance
- Replace them all on the leg in its environment according the E drawing.
- Press the button and keep it pressed until the green led is off, 3 seconds later when the green led has switched on again
- Release
- The green led will switch three times to indicate that the teaching has been going on. There are two possibilities :
  - **Either, the green led remains on** which means that the detector did recognise the item's position and is ready to run. Any item in its detection field within this control range will be detected
  - **Or, the green led flashes very quickly** which means that the teaching failed, i.e. that the requested distance is upon the authorised control range or there is no item facing the monitor. This can also mean that the supply was cut after the environment teaching. In that case, a reset has to be made and you will have to follow up again all the steps from the stage N°1.
- Remove the CDS80C off the elevator to put the adjustment element (orange) off.
- Replace the CDS80C on the opening, screw the four self locking nuts. It has now been brought into service.

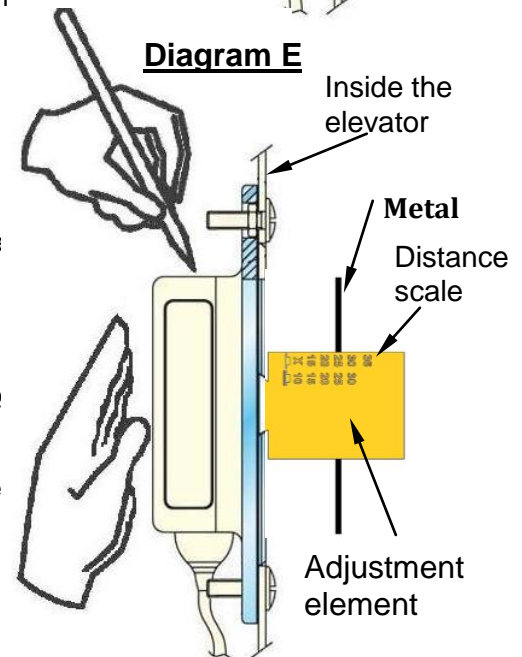

Normal running :	GREEN AND ORANGE LED ON (switch closed -NC)
Target entering sensor detection :	GREEN LED ON, ORANGE OFF (switch open - NO)
ELECTRIC DEFAULT :	NO LED

**Nota: To preset a new control range, you will have to follow up again all the above mentioned steps and have to begin first of all by a reset.**

- Unscrew the four locking nuts and remove the CDS80C off the shaft to take it away from any metallic mass.
- With a pin, press the button and keep it pressed until the green led is off, then about 3 seconds after it has switched during four seconds, once the led is off again, release the button.
- The sensor does not have now any remaining program

