



ENGINEERED INDUSTRIAL SAFETY SOLUTIONS



*Transitioning the World to a Safer Working Environment*



## Our History and Commitment to support our valued customer

**B**OSS PRODUCTS was founded in 2012 with a singular vision to assemble a complete offering of integrated energy saving, fire and explosion protection components for industrial filtration and process industries. We are committed to provide the highest quality products available, along with the technical support that is necessary to assist our growing select distribution and OEM customers. We proudly offer **THE LARGEST GROUPING OF NFPA COMPLIANT, FM, UL APPROVED & CERTIFIED PRODUCTS** available anywhere in the world. **BOSS PRODUCTS** began with a simple goal to deliver quality, competitively priced products from an "in stock" inventory.

**BOSS PRODUCTS** remains dedicated to expand its engineering, technical support and customer advocacy capabilities. We recognize that our customers appreciate a supplier that is committed to providing the before and after sale service that makes their job easier.



**BOSS PRODUCTS** moved operations to San Antonio, Texas in the spring of 2018. This transition from Washington State has given us the opportunity to establish a state of the art distribution, manufacturing and training facility. We invite our distribution family to visit **BOSS PRODUCTS** to show you some real Texas hospitality. Our mission is to become your distribution's single source for **ENERGY SAVING "SAFETY SMART" CONTROL SYSTEMS & FIRE AND EXPLOSION PROTECTION COMPONENTS**.

We continue to expand our in-house electronics manufacturing capability, building UL certified control panels for our **EcoMAXX®** brand and **OEM** manufacturers.

**BOSS PRODUCTS** is committed to a 2021 reintroduction of our **EcoBOSS® Energy Management Control Systems**. We recognize our responsibility to contribute to safety in the workplace and energy conservation.

[www.bossproductsamerica.com](http://www.bossproductsamerica.com)

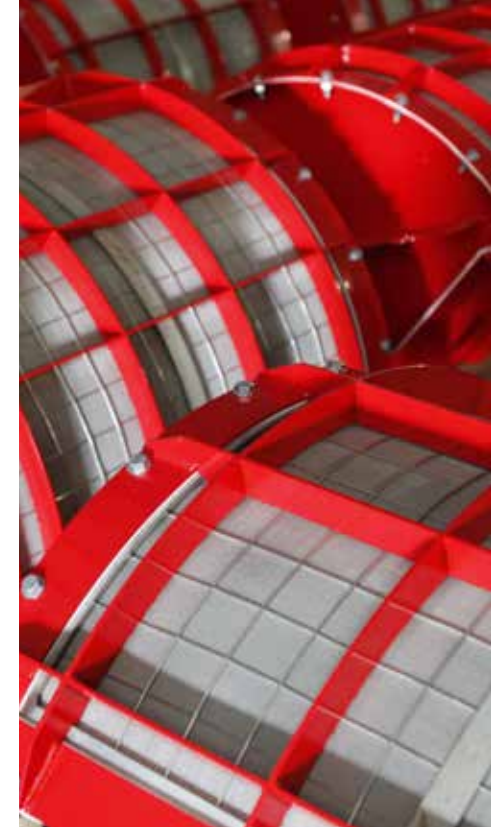

Agriculture & Grain



Food and Beverage

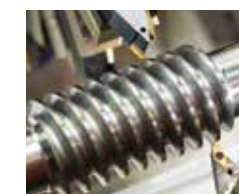

Metal Working



Pharmaceutical



Wood Processing



EV-VF p3



EM-NRV p7



EM-FV p9



EV-VDIV p11



EMVDL-RVEX p13



EV-VL VD VDHV p17



EV-VQ p23



RS-PCUSP1L p27



RS-PCU1610SD p27

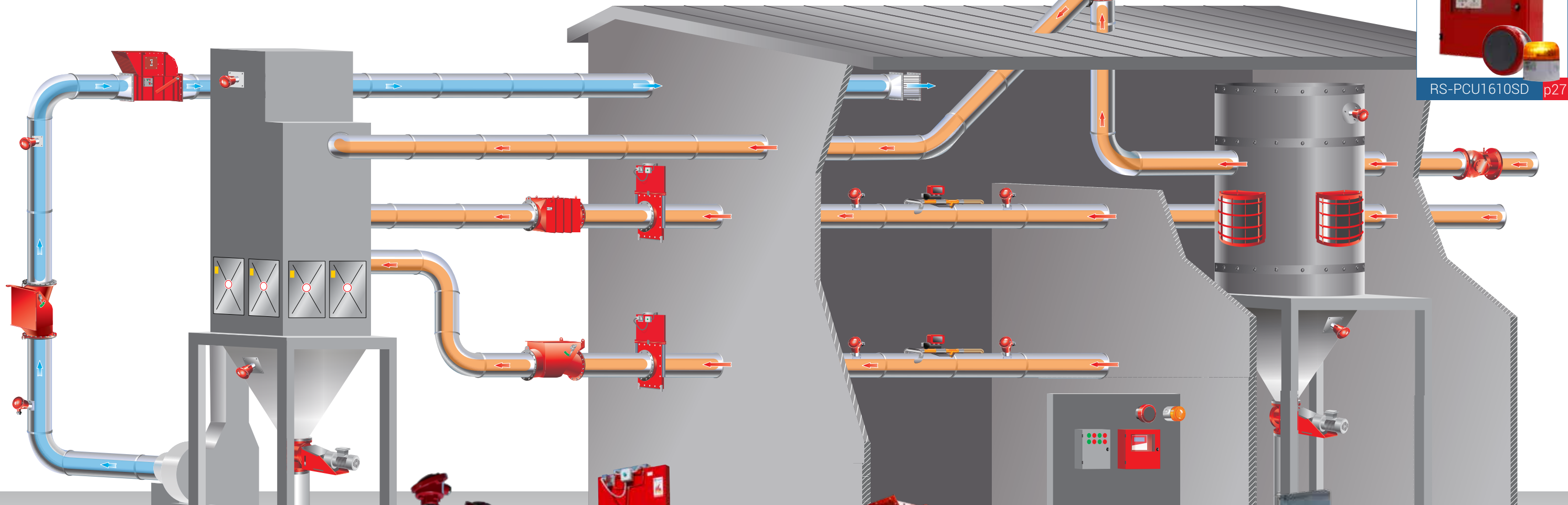

RS-EXT02 p29



RS-SD02  
RS-TL02 p30



RS-DP03  
RS-TP02 p31



EM-FBS p33



EM-HSAG02 p35



EB Control systems p39



EB-ABG p43



EB-BDHD p44

# Contents

FIRE & EXPLOSION MITIGATION	Product Code	Page
<b>EXPLOSION ISOLATION &amp; DIVERSION</b>		
Explosion Isolation Valve EV-VF VIGIFLAP	50200	3-8
No Return Valve EM-NRV	50100	9-10
Float Valve EM-FV	50700	11-12
Explosion Diverter EV-VDIV	50800	13-14
Certified Rotary Valve EMVDL-RVEX-HT	58000	15
Certified Rotary Valve EMVDL-RVEX-HTS	58100, 58101, 58102, 58103 & 58131	16
Certified Rotary Valve EMVDL-RVEX-MD	58200, 58204, 58205 & 58251	17
Certified Rotary Valve EMVDL-RVEX-BS	58500	18
Raptor Drum™ Explosion Tested Drum Kit	51301	19-20

## EXPLOSION VENTING

Flat Explosion Vent Panel EV-VL	51501	21-22
Domed Explosion Vent Panel EV-VD	51502	23-24
Sanitary Flat Explosion Vent Panel EV-VLSAN	51504	25-26
High Vacuum Domed Explosion Vent Panel EV-VD HV	51503	27-28
Explosion Vent Deflector EV-VS VIGISPACE	60401	29-32
Flameless Explosion Vent EV-VQ	60301 & 60305	33-34

FIRE & EXPLOSION MITIGATION	Product Code	Page
<b>EXPLOSION PREVENTION, FIRE PREVENTION, ISOLATION &amp; DIVERSION</b>		
Raptor Spark™ Spark Detection and Extinguishing System	56501, 56502, 56503 & 56504	37-38
Thermal Probe RS-TP02	56505	39
Dust Probe (Broken Bag Detector) RS-DP03	57502	40
Water Pressure Booster Pump RS-CPR	56506	41-42
Raptor Shield™ Spark Trap	51001	43-44
Raptor Breath™ CO <sub>2</sub> Fire Suppression Systems	51201	45-46
Raptor Gate™ Heavy Duty High Speed Abort Gate	56703	47-48
High Speed Abort Gate EM-HSAG02	56702	49-50
FireBreak Shutter EM-FBS	50301, 50302, 50303 & 50304	51-52

## CONTROLS & AUTOMATION

Product Code	Page
Introduction	53-54
Energy management control systems for Industrial dust collection & Ventilation	55001, 55010, 55020, 55030 & 55040
OEM Control Panel EB-OEM	80000
Automatic Blast Gate EB-ABG	55101
Heavy Duty Barometric Damper EB-BDHD	55601

## GRAIN ELEVATOR HAZARD MONITORING

Page
Introduction
M-JET Bearing/Belt Conveyor Hazard Monitoring
61-62
63-66

# Elements of Fire & Explosion

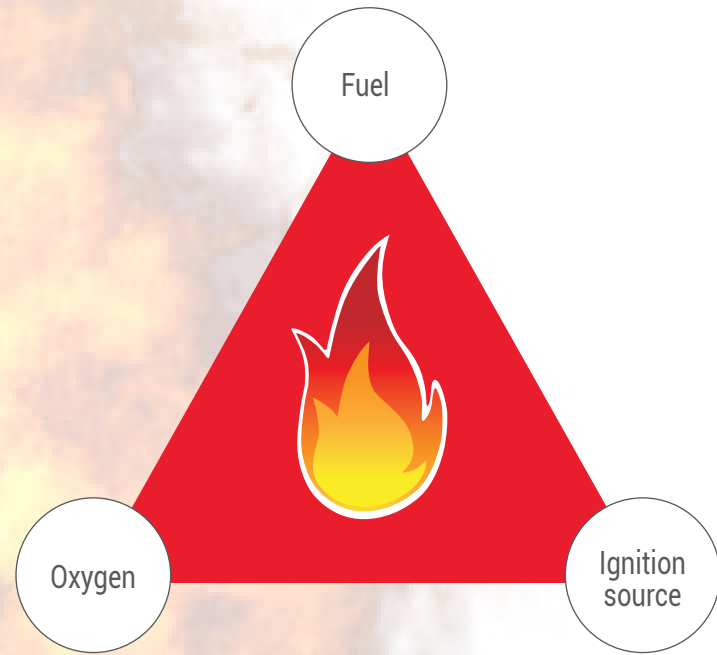

**M**anagement strategies for fire typically focus on the elimination/control of one of the **three key elements necessary for a fire** – the three key elements are often represented by the fire triangle. Managing one or more of the elements in the triangle can decrease the risk of a fire.

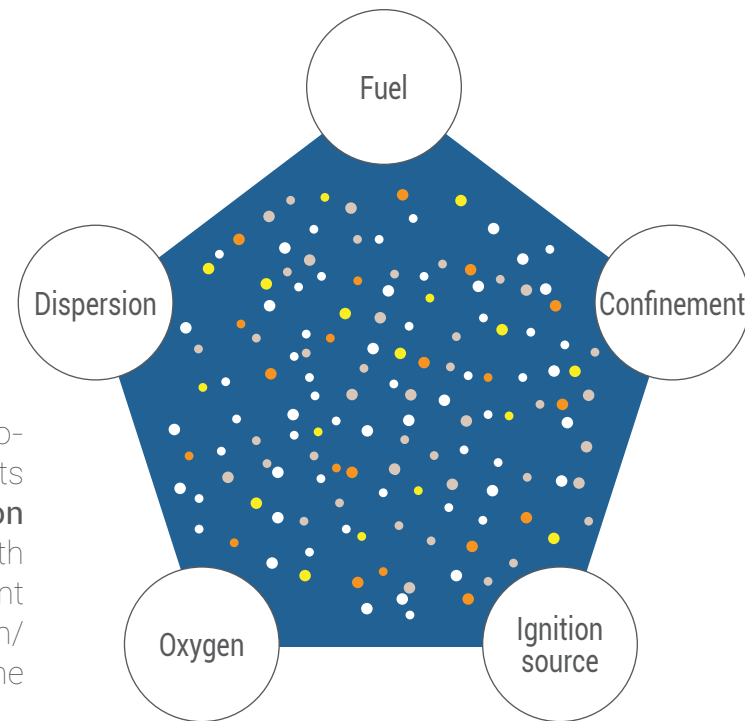

**M**anagement strategies for dust explosions typically consider 5 key elements – **fuel, heat, and oxygen, dispersion of dust and confinement of dust**. As with management strategies for fire, management strategies for explosions require the elimination/control of one or more of the elements in the explosion pentagon.

**B**OSS PRODUCTS engineers have decades of experience in the design and installation of multi-application industrial dust collecting, bulk handling & process systems. Today's NFPA regulatory guidelines governing fire & explosion protection installations are more specific and well defined than ever before.

**Boss Products'** strategies for Fire and Explosion mitigation include: **Prevention, Isolation, Diversion, and Venting.**

**Boss Products** has developed and brought to market a family of SAFETY SMART solutions to work as individual components or as a seamless plantwide solution to meet most needs.

**CERTIFICATIONS**  
 NFPA  
 ATEX  
 UL  
 EU Certificate  
 INERIS  
 Factory Mutual

The block contains a list of certifications and their corresponding logos: FM APPROVED (diamond logo), Ex (yellow hexagon logo), CE (two 'E' logos), and NFPA (flame logo).



# Explosion Isolation Valve EV-VF VIGIFLAP

## APPLICATIONS

The **EV-VF VIGIFLAP** is an explosion isolation valve designed to prevent propagation of overpressure or flame front caused by an explosion downstream in vessels such as dust collectors, cyclones, and filters.

The valve is held open either by air flow or proprietary locking mechanism. As a result, the **VIGIFLAP** valve can be used as an explosion isolation device for both the inlet and outlet of a vessel.

The **Explosion Isolation Valve EV-VF VIGIFLAP** complies with **NFPA** guidelines and is an **ATEX Certified** device for the containment of explosion.

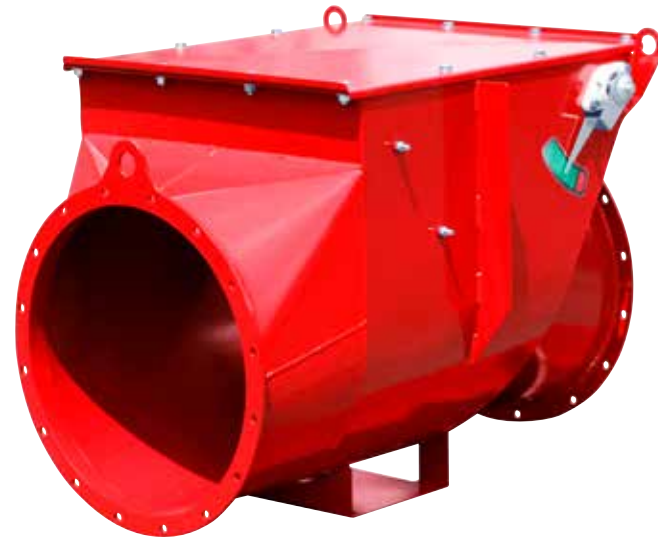

## DIMENSIONS

DIMENSIONS				
DN [inch]	DN [mm]	Door gasket	Body gasket	Body
ø 6	ø 160	EPDM	EPDM	Mild steel
ø 7	ø 180	EPDM	EPDM	Mild steel
ø 8	ø 200	EPDM	EPDM	Mild steel
ø 10	ø 250	EPDM	EPDM	Mild steel
ø 12	ø 300	EPDM	EPDM	Mild steel
ø 14	ø 350	EPDM	EPDM	Mild steel
ø 16	ø 400	EPDM	EPDM	Mild steel
ø 18	ø 450	EPDM	EPDM	Mild steel
ø 20	ø 500	EPDM	EPDM	Mild steel
ø 22	ø 550	EPDM	EPDM	Mild steel
ø 24	ø 600	EPDM	EPDM	Mild steel
ø 26	ø 650	EPDM	EPDM	Mild steel
ø 28	ø 700	EPDM	EPDM	Mild steel
ø 30	ø 750	EPDM	EPDM	Mild steel
ø 32	ø 800	EPDM	EPDM	Mild steel
ø 34	ø 850	EPDM	EPDM	Mild steel
ø 36	ø 900	EPDM	EPDM	Mild steel
ø 38	ø 950	EPDM	EPDM	Mild steel
ø 40	ø 1000	EPDM	EPDM	Mild steel
ø 42	ø 1050	EPDM	EPDM	Mild steel
ø 44	ø 1100	EPDM	EPDM	Mild steel
ø 46	ø 1150	EPDM	EPDM	Mild steel
ø 48	ø 1200	EPDM	EPDM	Mild steel
ø 50	ø 1250	EPDM	EPDM	Mild steel
ø 52	ø 1300	EPDM	EPDM	Mild steel

\* Units in inches rounded to the closest whole number

### CERTIFICATIONS & STANDARDS

EN 16447  
NFPA 69



### STANDARD FEATURES

- Body : painted steel
- 100% stainless steel AISI 304
- Diameters : ø6" to ø52" / ø160 mm to ø1320 mm
- Gasket : EPDM (Silicone FDA 392°F/180°C option)
- Pressure drop : Lower pressure drop with round domed flap

### OPTIONAL FEATURES

The EV-VF is 100% NFPA 69 compliant with the following optional features :

- **Body** : Galvanized steel
- **Body** : Stainless steel
- **Frame silicone FDA** : 392°F/200 °C
- Dust level sensor to prevent dust accumulation
- Connection box installed on the body, according to the ATEX zone (opposite side of the locking mechanism)



### MINIMUM INTERNAL DUST ACCUMULATION

The VigiFlap's unique inlet & outlet "Straight Through" design ensures very low static resistance and reduces dust accumulation.

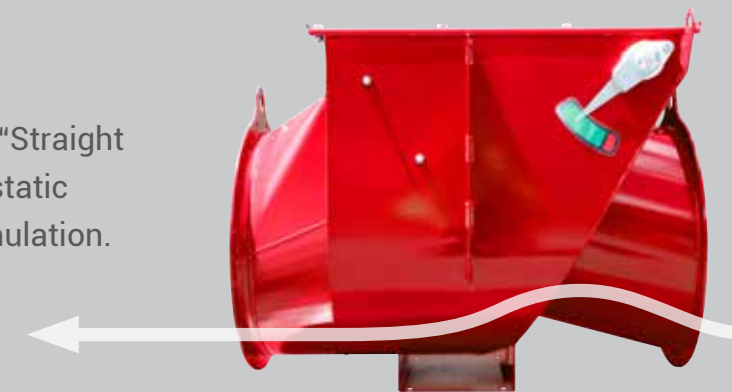

**FREE FLOW DESIGN**



# Explosion Isolation Valve EV-VF VIGIFLAP

## INSTALLATION

The VIGIFLAP EV-VF Valve has been tested and certified with the process pipe installed on up & downstream sides of the valve, simulating REAL WORLD CONDITIONS.

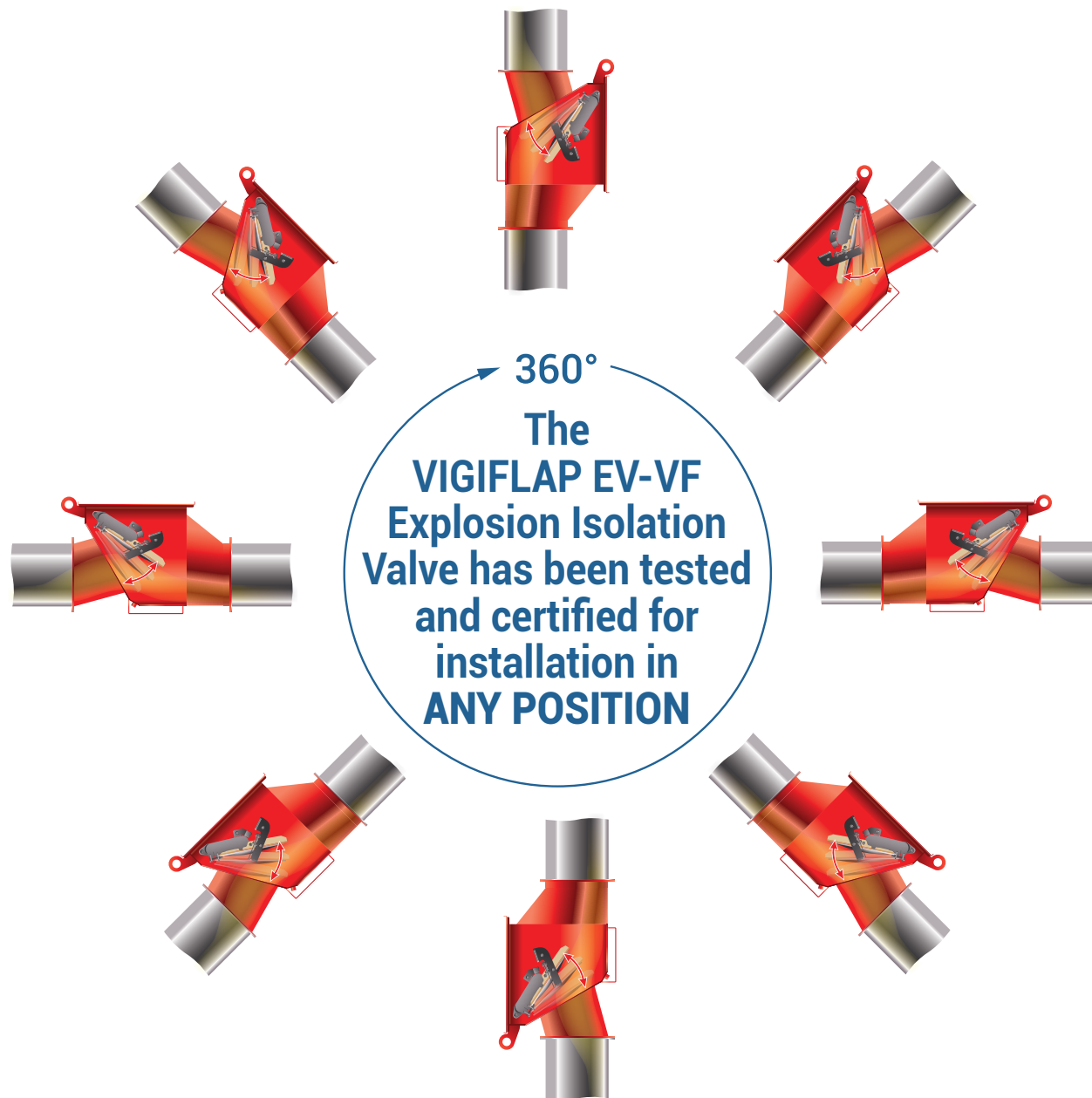

## PRESSURE DROP CURVES

PRESSURE DROP / In Flow Process (Dirty Air)

PRESSURE DROP / Reverse Process (Clean Air)

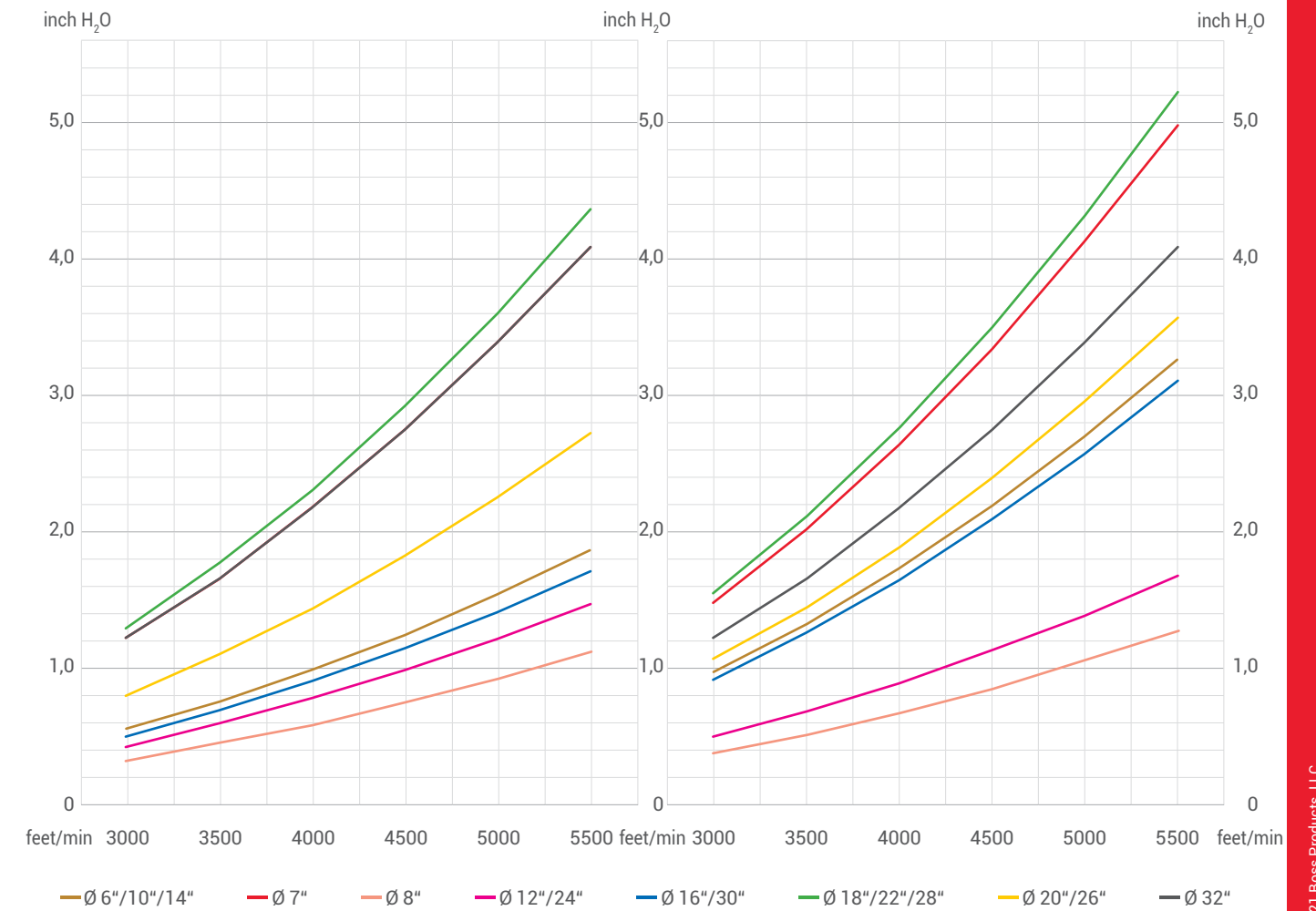
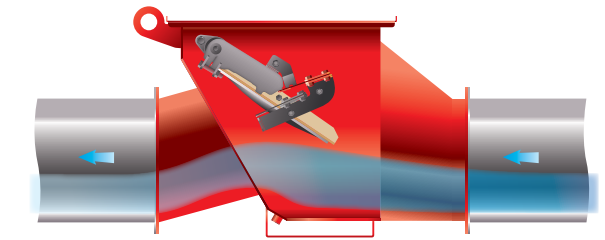
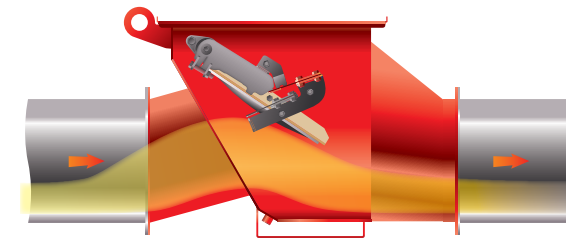



# Explosion Isolation Valve EV-VF VIGIFLAP

## PROCESS FLOW POSITIONS

### PROCESS FLOW

FLOW POSITIONS :

**1** Flap is held open by process flow

Installation with floating flap

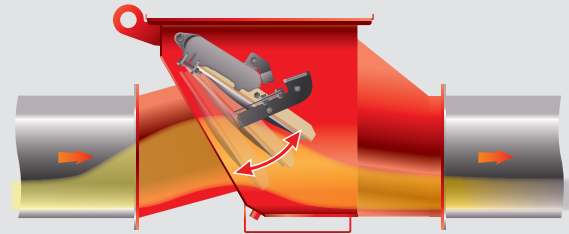

**2** Flap locked in open position

Installation with flap locked open

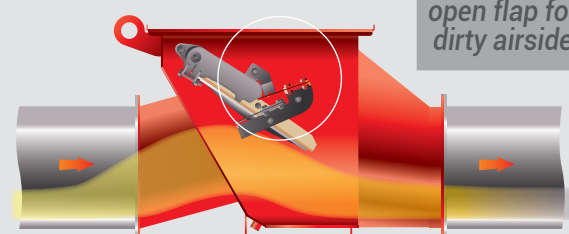

Locked open flap for dirty airside

Locked open flap for clean airside



### EXAMPLE DURING AN EXPLOSION EVENT

Explosion isolation is achieved by flap closure independent of being in free floating or locked open position

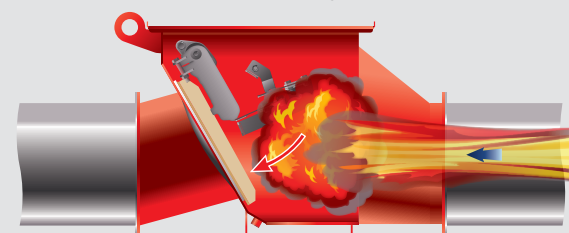

Manual locking mechanism reset is required

## TECHNICAL INFORMATION

KST MAX	ST3 > 250 bar.m/s	AMBIENT TEMPERATURE	-4°F... +140°F -20°C... +60°C	FLUX	Overpressure or vacuum
P MAX	145 psi ≤ 10 bar	SPEED FLOW	2950-6890 fpm 15m/s... 30m/s	INTERIOR	ATEX zone 20
MESG	1/16" 1.5 mm (ex: sulfur)	DUST CONCENTRATION	No limit	OPERATING TEMPERATURE	EPDM gasket : -30° C + 70° C Silicone gasket : -10° C + 180° C
DUST	Any kind of dust	POSITION OF THE DEVICE	Vertical / Horizontal		

## INSTALLATION EXAMPLES

THE EXPLOSION ISOLATION VALVE VIGIFLAP IS DESIGNED FOR USE ON THE INLET AND OUTLET SIDES OF A FILTER OR VESSEL

PROCESS FLOW (The VIGIFLAP is always set in the open locked position when installed on the clean air or positive pressure side of a filter)

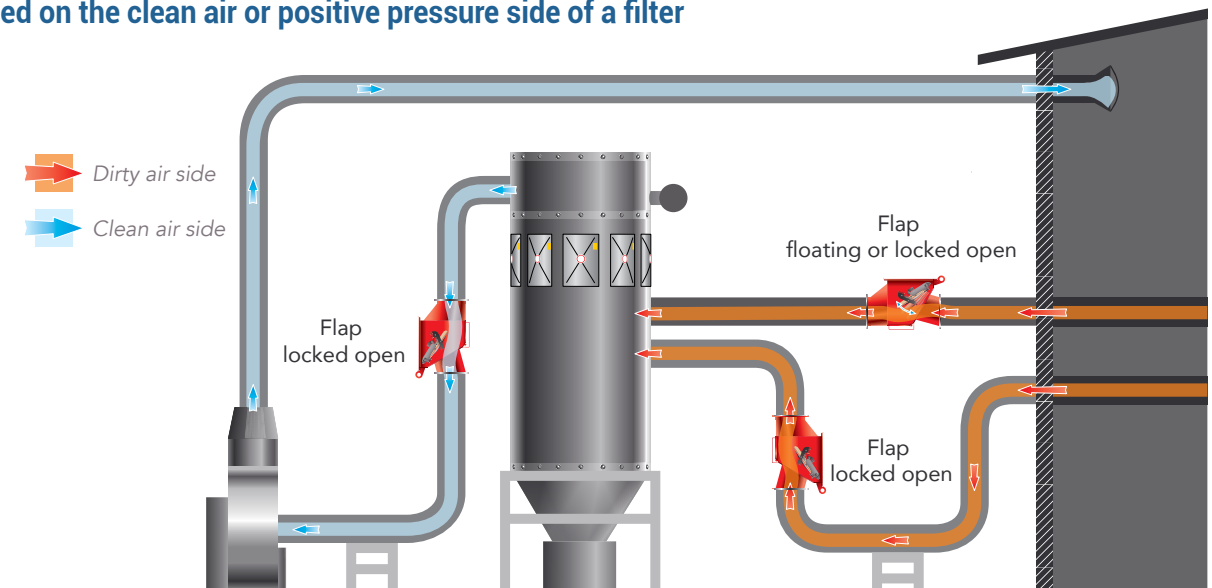

### DEFLAGRATION EXPLOSIVE EVENT

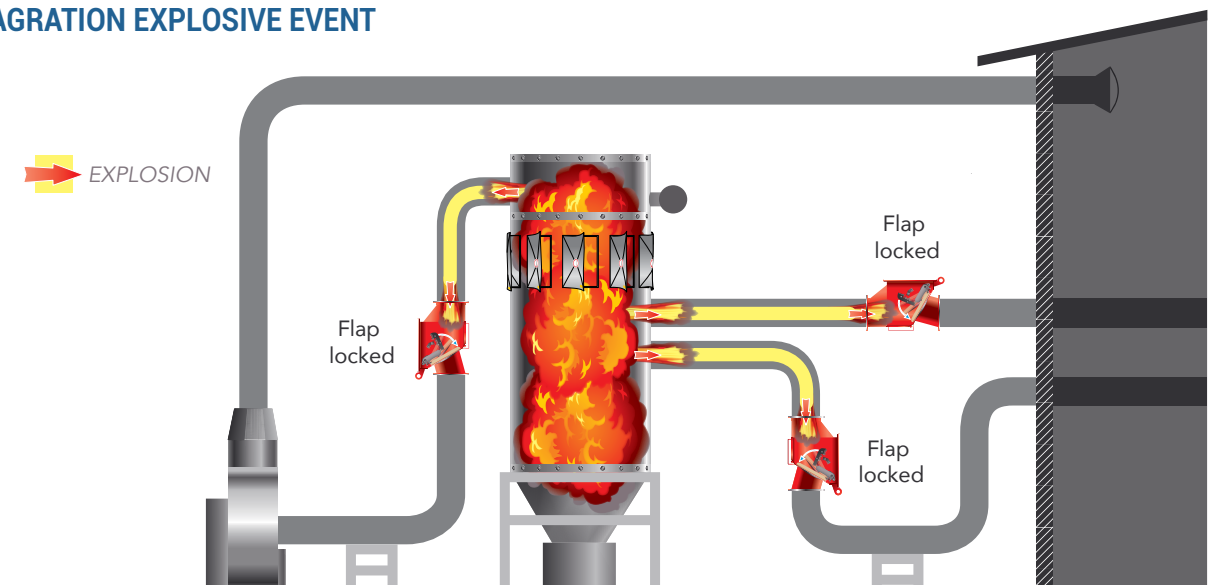



# No Return Valve EM-NRV

## APPLICATIONS

The installation of an explosion isolation device on all suction side ducts that transport material with a Kst value above zero is an **NFPA Requirement**.

Installing a **No Return Valve EM-NRV** will protect workers and facilities from the damaging effect of a baghouse or filter explosion.

The **No Return Valve EM-NRV** is designed for use with all EcoMAXX® High Speed Abort Gates, Fire Break Shutters, Raptor Spark Detection & Extinguishing/Suppression Systems, and Energy Management Systems.



### CERTIFICATIONS & STANDARDS

EN 16447  
NFPA 69



### STANDARD FEATURES

- Heavy-duty welded steel construction
- Flanged inlet and outlet with co-flanges
- Inspection/access door
- Grounding lug
- Locking mechanism

### OPTIONAL FEATURES

The EM-NRV is 100% NFPA 69 compliant with the following optional features :

- EM-NRV-MS – Micro-switch for system shut down
- EM-NRV-DLS – Dust Level Sensor
- EM-NRV-CP04 – Intrinsically safe control panel for sensor power and integration with existing, new or EcoBOSS® Control Panel



## DIMENSIONS

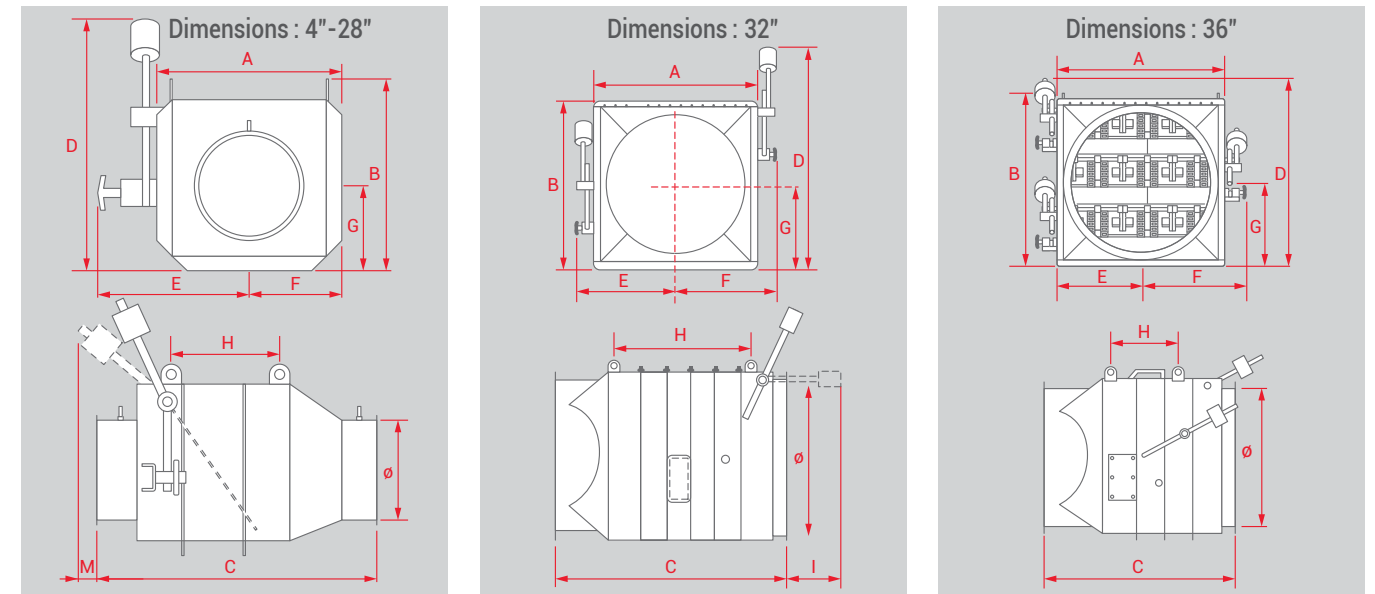

### NO RETURN VALVE (NRV) DIMENSIONS (SIZES 4" - 28")

Ø	A	B	C	D	E	F	G	H	I	LBS
SIZES 4" - 16" RATED FOR : Class ST2 Applications – Kst max 270 bar m/s – Pred max 0.50 bar – Certification EN 16447										
100mm/4"	7.7	6.8	15.0	8.7	9.1	3.8	3.0	0.0	0.0	40
125mm/5"	8.7	7.8	16.0	9.6	9.6	4.3	3.3	0.0	0.0	40
160mm/6"	14.2	13.4	21.7	17.7	11.8	7.1	6.7	0.0	3.0	45
180mm/7"	14.2	13.4	21.7	19.7	11.8	7.1	6.7	0.0	3.0	45
200mm/8"	14.2	13.4	21.7	19.7	11.8	7.1	6.7	0.0	3.0	45
250mm/10"	16.1	15.4	23.6	22.4	12.8	8.1	7.7	0.0	3.1	56
300mm/12"	18.1	17.3	26.4	23.6	13.8	9.1	8.7	0.0	3.1	84
350mm/14"	20.1	19.3	28.3	25.6	14.8	10.0	9.6	11.8	3.1	100
400mm/16"	22.0	23.2	30.3	29.5	15.7	11.0	11.2	13.5	5.1	120
SIZES 18" - 28" RATED FOR : Class ST2 Applications – Kst max 260 bar m/s – Pred max 0.50 bar – Certification EN 16447										
450mm/18"	24.0	25.2	33.1	33.3	16.7	12.0	11.6	15.7	7.1	150
500mm/20"	26.0	27.2	34.3	38.8	17.7	13.0	12.6	18.1	10.6	177
550mm/22"	28.0	29.1	36.2	37.4	18.7	14.0	13.6	19.7	7.1	221
600mm/24"	29.9	31.1	38.2	41.1	19.7	15.0	14.6	21.7	11.4	254
650mm/26"	31.9	33.1	40.2	45.1	20.7	15.9	15.6	23.8	13.4	276
700mm/28"	33.9	35.0	42.1	47.0	21.7	16.9	16.5	25.6	11.0	298

### NO RETURN VALVE (NRV) DIMENSIONS (SIZES 32" - 36")

Ø	A	B	C	D	E	F	G	H	I	LBS
SIZE 32" RATED FOR : Class ST2 Applications – Kst max 240 bar m/s – Pred max 0.25 bar – Certification EN 16447										
800mm/32"	38.6	40.4	52.5	56.5	26.0	26.0	18.9	28.1	14.2	728
SIZE 36" RATED FOR : Class ST3 Applications – Kst max 330 bar m/s – Pred max 0.50 bar – Certification EN 16447										
900mm/36"	42.5	44.3	44.7	60.4	28.0	28.0	20.9	28.1	14.2	860

### NO RETURN VALVE (NRV) COMBO DIMENSIONS (SIZES 40" - 48")

Ø	A	B	C	D	E	F	G	H	I	LBS
SIZE 40"-48" RATED FOR : Class ST3 Applications – Kst max 325 bar m/s – Pred max 0.50 bar – Certification EN 16447										
1000mm/40"	46.5	48.6	47.8	60.0	31.9	63.6	23.0	24.0	10.2	893
1100mm/44"	50.4	52.2	51.0	63.1	33.9	67.5	25.0	28.3	10.2	1058
1200mm/48"	54.3	56.1	54.1	67.9	35.8	71.5	27.0	31.3	10.2	1179



# Float Valve EM-FV

## APPLICATIONS

The **Float Valve EM-FV** is designed as an explosion isolation device in air streams with low to low moderate dust concentrations. The maximum allowed recommended particle size is approximately **500 microns**. A regular inspection and maintenance schedule is required to ensure that dust deposits that could interfere with the valve's function are not accumulating.



### CERTIFICATIONS & STANDARDS

EN 15089  
NFPA 69



## TECHNICAL INFORMATION

ORGANIC DUST	St1 ≤ 200 bar.m/s St2 ≤ 300 bar.m/s	MAXIMUM EXPLOSION OVERPRESSURE	160 psi 11 bar	STAINLESS STEEL	-4 °F to +482 °F -20 °C to +250 °C >250 °C / 482 °F on request
GAS	kg ≤ 100 bar.m/s	HUMIDITY	10 – 90% R.H. (non-condensing)	PROCESS PRESSURE	12 psi ≤ pR ≤ 16 psi 800 mbar ≤ pR ≤ 1100 mbar
HYBRID MIXTURE IIA AND ETHANOL	120% LEL	OPERATING TEMPERATURES	Aluminum -4 °F to +248 °F -20 °C to +90 °C	FLOW SPEED IN THE EXPLOSION DIRECTION	1970 - 5905 fpm 10 - 30 m/s
HYBRID MIXTURE IIA+IIB	80% LEL / 120% LEL	STEEL	-4 °F to +194 °F -20 °C to +120 °C	CONTRARY TO THE EXPLOSION DIRECTION	6890 fpm max. 35 m/s

## FLOAT VALVE ACTUATION

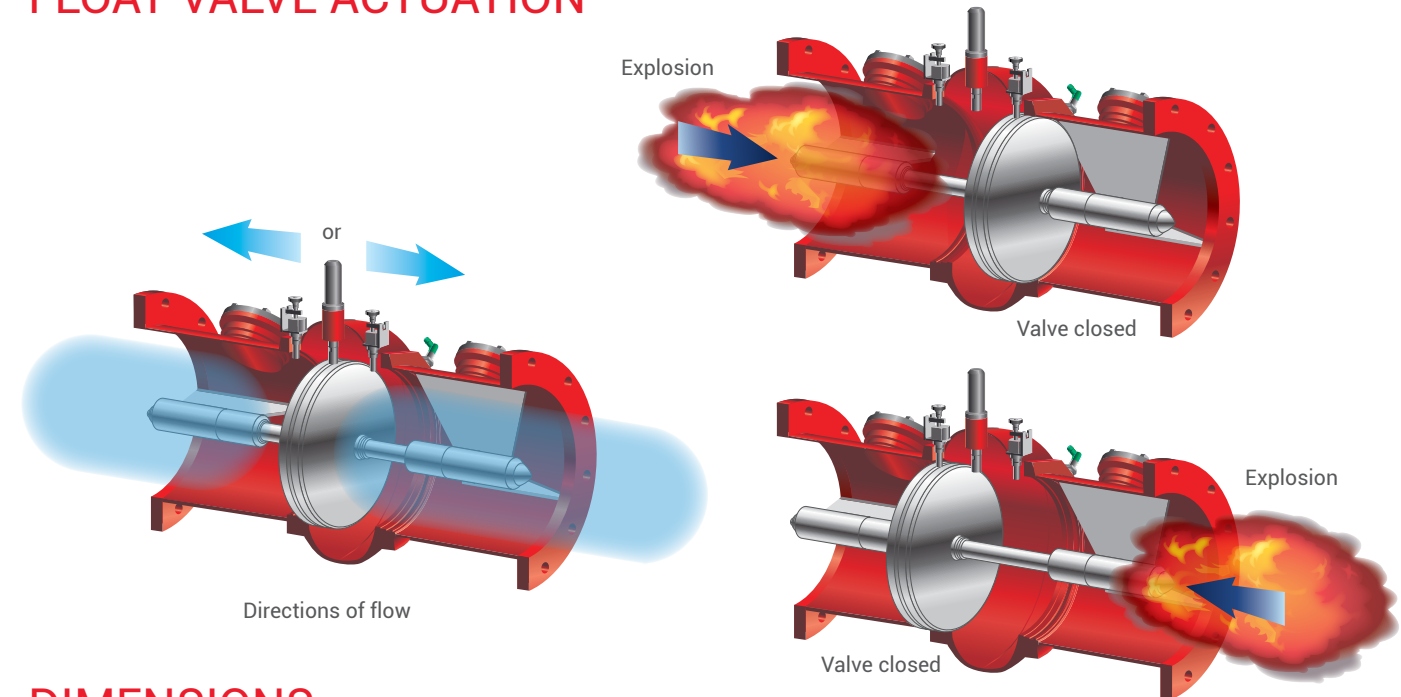

## DIMENSIONS

		TECHNICAL DATA									
MODEL DIAMETER	DN	50	80	100	150	200	250	300	400	500	
	Inch	2"	3"	4"	6"	8"	10"	12"	16"	20"	
Min. explosion pressure	psi/mbar	0.70/50									
Max. explosion pressure at 68°F / 20°C	psig/bar abs	191/12 (increased operating temperature results in reduced strength)									
Air speed in direction of explosion	fpm / m/s	1970 - 5905 / 10 - 30									
Air speed in the direction against the explosion	fpm / m/s	6890 / 35									
Organic dusts	max. Kst	bar*m*s <sup>-1</sup> 300									
	min. installation distance	ft/m	7/2	7/2	7/2	7/2	10/3	10/3	10/3	10/3	10/3
	max. installation distance	ft/m	40/12	40/12	40/12	40/12	40/12	40/12	40/12	40/12	40/12
Gas < vapors, gas group IIB	max. Kst	bar*m*s <sup>-1</sup> 300									
	min. installation distance	ft/m	7/2	7/2	7/2	7/2	10/3	10/3	10/3	10/3	10/3
	max. installation distance	ft/m	26/8	26/8	26/8	26/8	8 26/8	26/8	26/8	26/8	26/8
Hybrid mixtures (Proportion of gas below the LEL)	max. Kst	bar*m*s <sup>-1</sup> 300									
	min. installation distance	ft/m	7/2	7/2	7/2	7/2	10/3	10/3	10/3	10/3	10/3
	max. installation distance	ft/m	40/12	40/12	40/12	40/12	40/12	40/12	40/12	40/12	40/12

Dimensions are rounded to the closest whole number



# Explosion Diverter EV-VDIV

## APPLICATIONS

The **Explosion Diverter EV-VDIV** valve with an explosion panel is the ideal addition to any exterior process flow duct system where there is potential for hazardous explosive overpressure or multiple explosive events. This device helps reduce the potential for system damage caused by high overpressure and rapid flame front expansion.



## DIMENSIONS

### CHARACTERISTICS OF THE EXPLOSION DEFLECTION DEVICE

Number of panels	ø [in/mm]	H1	H2	D1	D2	L1	L2	T	Panel dimensions
x1	8/200	6/150	22/555	8/200	16/410	16/410	16/410	27/685	VD 16"x16" - 410x410mm
	10/250	7/175	24/600	10/250	20/490	20/490	20/490	31/781	VD 19"x19" - 490x490mm
	12/300	8/200	28/700	12/300	24/610	24/610	24/610	35/875	VD 24"x24" - 610x610mm
	14/350	9/225	32/800	14/350	26/645	26/645	26/645	39/975	VD 25"x25" - 645x645mm
	16/400	10/250	36/900	16/400	31/780	31/780	31/780	43/1070	VD 31"x31" - 780x780mm
x2	18/450	11/275	40/1000	18/450	34/850	37/920	37/920	47/1165	VD 17"x35" - 457x890mm (Qty. 2)
	20/500	12/300	44/1100	20/500	37/920	37/920	37/920	50/1260	VD 17"x35" - 457x890mm (Qty. 2)
	22/550	13/325	48/1200	22/550	39/980	39/980	39/980	54/1355	VD 17"x35" - 457x890mm (Qty. 2)
	24/600	14/350	52/1300	24/600	43/1070	41/1020	41/1020	58/1455	VD 23"x36" - 586x920mm (Qty. 2)
	26/650	15/375	56/1400	26/650	47/1180	47/1180	47/1180	62/1550	VD 23"x36" - 586x920mm (Qty. 2)
x4	28/700	16/400	60/1500	28/700	50/1250	55/1375	55/1375	66/1645	VD 24"x24" - 610x610mm (Qty. 4)
	30/750	17/425	64/1600	30/750	54/1350	58/1455	58/1455	70/1740	VD 24"x24" - 610x610mm (Qty. 4)
	32/800	18/450	68/1700	32/800	57/1430	58/1455	58/1455	73/1835	VD 25"x25" - 645x645mm (Qty. 4)
	34/850	19/475	72/1800	34/850	61/1520	64/1605	64/1605	77/1930	VD 23"x36" - 586x920mm (Qty. 4)
	36/900	20/500	76/1900	36/900	64/1600	64/1605	64/1605	81/2030	VD 23"x36" - 586x920mm (Qty. 4)
x6	38/950	21/525	80/2000	38/950	68/1700	71/1785	71/1785	85/2125	VD 17"x35" - 457x890mm (Qty. 6)
	40/1000	22/550	84/2100	40/1000	71/1780	71/1785	71/1785	89/2220	VD 22"x34" - 530x850mm (Qty. 6)

Dimensions are rounded up to the closest whole number

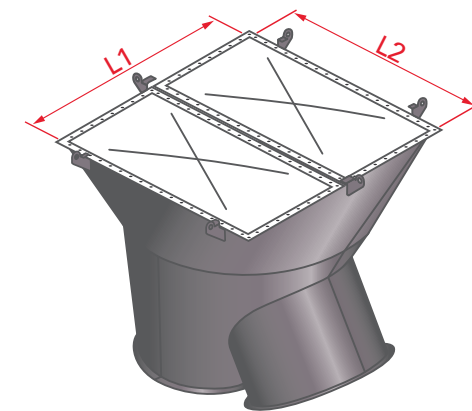
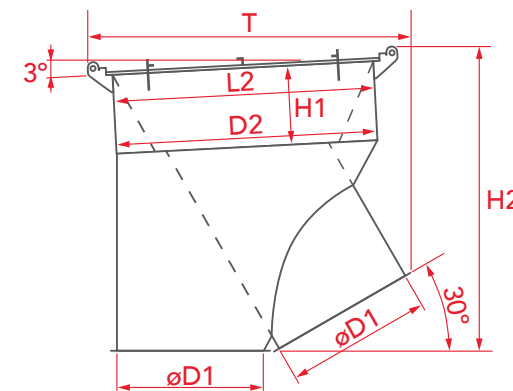

### CERTIFICATIONS & STANDARDS

EN 14491  
EN 14797  
NFPA 69



### STANDARD FEATURES

- Flat explosion vent panel VL or domed explosion vent panel VD

### OPTIONAL FEATURES

- Stainless steel construction

## TECHNICAL INFORMATION

MODEL	KST MAX	Pred. Max	PMAX	DUST
EV-VDIV	St2 ≤ 300 bar.m/s	12 psi 0.8 bar	174 psi ≤ 12 bar	Any kind of dust



# Certified Rotary Valve EMVDL-RVEX-HT

PRODUCT CODE: 58000

## APPLICATIONS

- Passive explosive isolation. ATEX EN 15089 / NFPA 69
- Differential pressures up to 40" WG
- Rotary airlock for dust collectors and cyclones
- Feeder valve for screw conveyors, scales, dryers and coolers

### CERTIFICATIONS & STANDARDS

EN 15089  
 CE 0588 Ex II ID/\* c T4 Ex D FSA 15 ATEX 1661/1662 X  
 NFPA 69 compliant  
 Flex tip design certified to prevent flame passage  
 NFPA 69 12.2.4.3.6 compliant



### STANDARD FEATURES

- Explosion & Flame Proof design rated up to 25 psi / 1.7 bar
- Cast iron body with flanged round inlet/outlet
- NFPA 69 Compliant with 8 blade rotor, polyurethane flex-tips
- External oil / bronze bearings with felt shaft seal
- 15 RPM direct drive gearmotor with flex coupling, USA Mfg

### OPTIONAL FEATURES

- Motors for hazardous locations and extreme temperature
- 30 RPM gearmotor with EM variable speed control package
- Special construction such as stainless steel, chromium or nickel plating, quick disassembly
- Insulation box, speed monitors, flange gasket, injector fittings and product scrapers

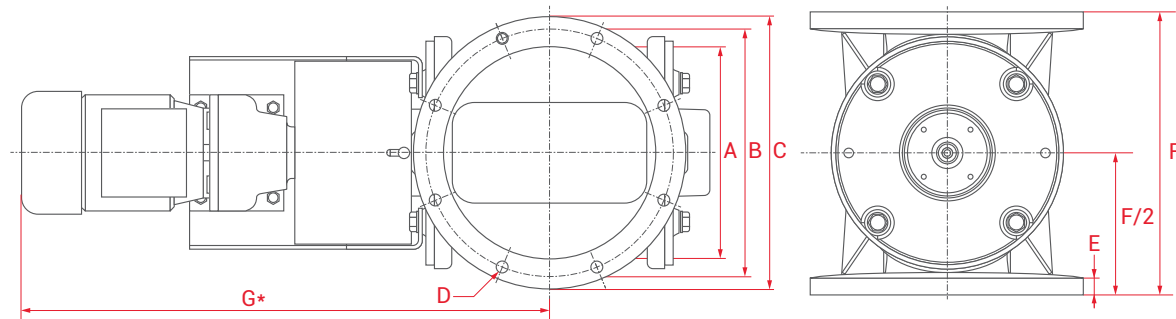

DIMENSIONS*										
MODEL	15 RPM HP	30 RPM HP	CAPACITY FT <sup>3</sup> (LTR)	Ø A	Ø B	Ø C	D	E	F*	G
EMVDL RVEX-HT250	0.33	0.75	0.24 (7)/rev	10" (250 mm)	12" (290 mm)	13" (320 mm)	8 x Ø12 mm	0.79" (20 mm)	13" (330 mm)	24" (620 mm)
EMVDL RVEX-HT350	0.50	1.00	0.70 (20)/rev	14" (340 mm)	15" (390 mm)	17" (420 mm)	8 x Ø12 mm	0.79" (20 mm)	16" (400 mm)	26" (670 mm)
EMVDL RVEX-HT450	1.00	2.00	1.23 (35)/rev	17" (420 mm)	19" (490 mm)	21" (525 mm)	8 x Ø12 mm	0.79" (20 mm)	20" (500 mm)	33" (850 mm)

SQUARE TO ROUND TRANSITIONS*						
SQUARE TRANSITION (Nominal Size Inches)	6X6	8X8	10X10	12X12	14X14	16X16
Model : EMVDL-RVEX	HT250	HT250	HT250	HT350	HT350	HT450
Transition Height	2.84" (72 mm)	2.80" (71 mm)	2.80" (71 mm)	2.80" (71 mm)	2.80" (71 mm)	3.43" (87 mm)
Overall Height (Dim F + Transition Height)	16" (402 mm)	16" (401 mm)	16" (401 mm)	19" (471 mm)	19" (471 mm)	23" (587 mm)

\* Length varies dependent on motor selection – Units in inches rounded to the closest whole number



# Certified Rotary Valve EMVDL-RVEX-HTS

PRODUCT CODES: 58100, 58101, 58102, 58103 & 58131

## APPLICATIONS

- Passive explosion isolation, ATEX EN 15089 / NFPA 69
- Rotor selections for dry, corrosive & sticky material
- Tested for high vacuum applications up to 160" WG
- Ideal for dust collectors, cyclones, silos, hoppers & specialized process applications

### CERTIFICATIONS & STANDARDS

EN 15089  
 CE 0588 Ex II ID/\* c T4 Ex D FSA 15 ATEX 1661/1662 X  
 NFPA 69 compliant  
 Flex tip design certified to prevent flame passage  
 NFPA 69 12.2.4.3.6 compliant



### STANDARD FEATURES

- Explosion & Flame Proof design rated up to 36 psi / 2.5 bar (25 psi / 1.7 bar with polyurethane flex tip rotor)
- Cast iron body with flanged inlet and outlet
- NFPA Compliant with 8 blade polyurethane flex tip rotor
- NFPA Compliant with 8 blade steel or S/S construction
- Dust tight ball bearings & shaft seal with adjustable packing
- 15 RPM direct drive gearmotor w/flex coupling, IP65, USA mfg

### OPTIONAL FEATURES

- Motors for hazardous locations and extreme temperature
- 30 RPM gearmotor with EM variable speed control package
- Square to round flange adapter incl. gasket and mounting bolts
- S/S construction, quick disassembly, and specialized coatings
- Insulation box, speed monitor, injector fittings and scrapers

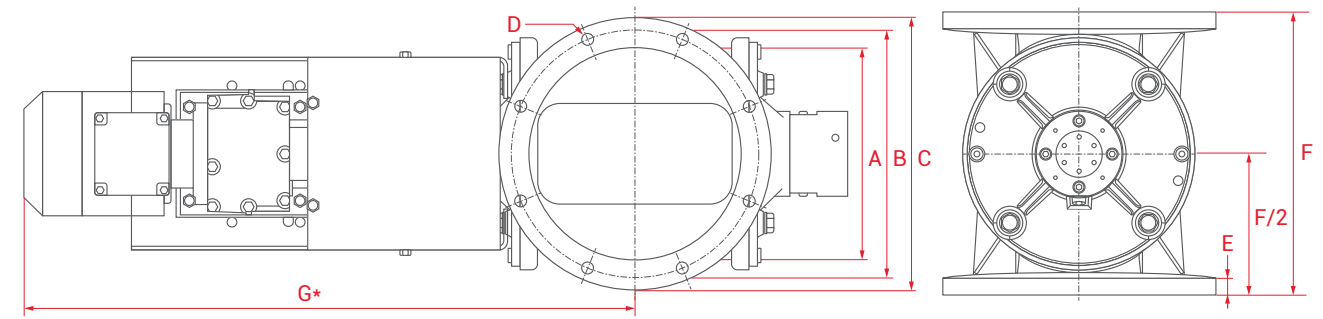

DIMENSIONS*										
MODEL	15 RPM HP	30 RPM HP	CAPACITY FT <sup>3</sup> (LTR)	Ø A	Ø B	Ø C	D	E	F*	G
EMVDL RVEX-HTS250	0.33	0.75	0.24 (7)/rev	10" (250 mm)	12" (290 mm)	13" (320 mm)	8 x Ø12 mm	0.79" (20 mm)	13" (330 mm)	28" (710 mm)
EMVDL RVEX-HTS350	0.50	1.00	0.70 (20)/rev	14" (340 mm)	15" (390 mm)	17" (420 mm)	8 x Ø12 mm	0.79" (20 mm)	16" (400 mm)	33" (830 mm)

SQUARE TO ROUND TRANSITIONS*					
SQUARE TRANSITION (Nominal Size Inches)	6X6	8X8	10X10	12X12	14X14
Model : EMVDL-RVEX	HTS250	HTS250	HTS250	HTS350	HTS350
Transition Height	2.84" (72 mm)	2.80" (71 mm)	2.80" (71 mm)	2.80" (71 mm)	2.80" (71 mm)
Overall Height (Dim F + Transition Height)	16" (402 mm)	16" (401 mm)	16" (401 mm)	19" (471 mm)	19" (471 mm)

\* Length varies dependent on motor selection – Units in inches rounded to the closest whole number



# Certified Rotary Valve EMVDL-RVEX-MD

PRODUCT CODES: 58200, 58204, 58205, & 58251

## APPLICATIONS

- Passive explosion isolation requiring rotor access for frequent cleaning
- Differential pressures **up to 400" WG**
- Heavy Duty design, ideal for high vacuum applications
- Recommended for pneumatic conveying of process material and dust feeder valve for screw conveyors, scales, classifiers dryers and coolers

### CERTIFICATIONS & STANDARDS

EN 15089  
 CE 0588 Ex II ID/\* c T4 Ex D FSA 15 ATEX 1661/1662 X  
 NFPA 69 compliant  
 Flex tip design certified to prevent flame passage  
 NFPA 69 12.2.4.3.6 compliant

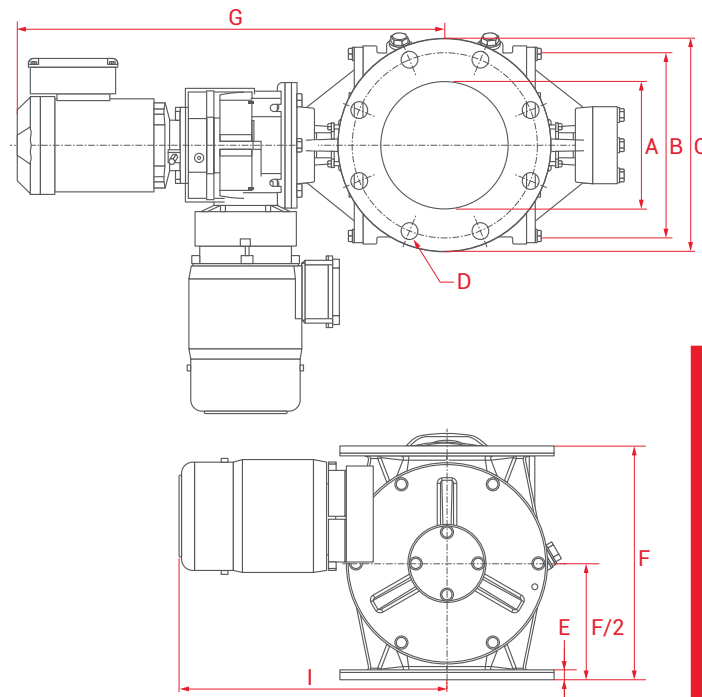

### STANDARD FEATURES

- Explosion & Flame Proof design to **36 psi / 2.5 bar** (25 psi / 1.7 bar with polyurethane flex tip rotor)
- Cast iron housing with round inlet and outlet
- Direct Drive **15 RPM, IP65 gearmotor** w/flex coupling
- Removable 8 vane polyurethane, steel or S/S rotor
- Adjustable Gland Pack bearings for shaft sealing
- High fill ratio with very low leakage & product damage

### OPTIONAL FEATURES

- Motors for hazardous locations and extreme temperature
- 30 RPM gearmotor** with EM variable speed control package
- Special construction, stainless steel, chromium/nickel plating
- Insulation box, speed monitors, flange gasket, injector fittings and product scrapers

#### DIMENSIONS \*

MODEL	15 RPM HP	30 RPM HP	CAPACITY FT <sup>3</sup> (LTR)	Ø A	Ø B	Ø C	D	E	F	G	H	I
EMVDL RVEX-MD150	0.50	0.75	0.10 (3)/rev	6" (150 mm)	9" (240 mm)	11" (285 mm)	8 x Ø23 mm	0.51" (13 mm)	10" (260 mm)		13" (330 mm)	14" (355 mm)
EMVDL RVEX-MD200	0.75	1.50	0.39 (11)/rev	8" (200 mm)	12" (300 mm)	13" (340 mm)	8 x Ø23 mm	0.51" (13 mm)	15" (370 mm)		16" (400 mm)	21" (525 mm)
EMVDL RVEX-MD250	1.00	1.00	0.74 (21)/rev	10" (250 mm)	14" (350 mm)	16" (395 mm)	12 x Ø23 mm	0.67" (17 mm)	17" (425 mm)	30" (770 mm)		
EMVDL RVEX-MD300	1.50	3.00	1.30 (37)/rev	12" (300 mm)	16" (400 mm)	18" (445 mm)	12 x Ø23 mm	0.79" (20 mm)	20" (500 mm)	33" (840 mm)		

Columns G, H and I depend on drive

\* Units in inches rounded to the closest whole number

# Certified Rotary Valve EMVDL-RVEX-BS

PRODUCT CODE: 58500

## APPLICATIONS

- Passive explosion and flame isolation
- Differential pressures **up to 28" WG**
- Ideal for wood applications w/flex-tip rotor
- Rotary airlock for dust collectors and cyclones

### CERTIFICATIONS & STANDARDS

ATEX 1D/2D T4 safety system  
 CE 0588 Ex II 1D/2D T4 (Device Inside/Outside) Ex D (Protective system) FSA 15 ATEX 1658 X  
 NFPA 69 compliant  
 Flex tip design certified to prevent flame passage  
 NFPA 69 12.2.4.3.6 compliant



### STANDARD FEATURES

- Explosion and flame isolation **up to 7 psi / 0.5 bar**
- 8 vane flex-tip NFPA 69** compliant rotor, Ex/flame proof
- 15 RPM, IP65** direct drive gear motor with flex coupling
- Inlet/ discharge size **20" X 20", 20" X 30" & 20" X 40"**
- Requires system integrated control panel for ATEX certification

### OPTIONAL FEATURES

- Motors for hazardous locations and extreme temperature
- 30 RPM gearmotor** with EM variable speed control package
- EM system integration package required for ATEX certification
- Stainless steel construction, Insulation box, speed monitor, flange gasket

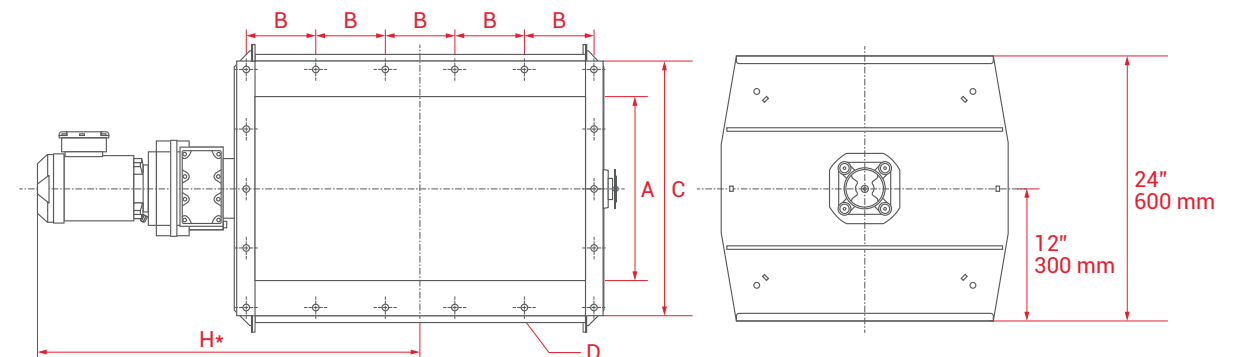

#### DIMENSIONS \*

MODEL	15 RPM HP	30 RPM HP	CAPACITY FT <sup>3</sup> (LTR)	A	B	C	D	H
EMVDL RVEX-BS500	1.00	2.00	4.41 (125)/rev	20" x 20" (500 x 500 mm)	0.16" x 5.30" (4 x 135 mm)	23" x 23" (580 x 580 mm)	16 x Ø 10.5 mm	30" (742 mm)
EMVDL RVEX-BS750	1.00	2.00	6.64 (188)/rev	20" x 30" (500 x 750 mm)	0.20" x 6.22" (5 x 158 mm)	23" x 33" (580 x 830 mm)	18 x Ø 10.5 mm	34" (867 mm)
EMVDL RVEX-BS1000	1.50	3.00	8.83 (250)/rev	20" x 40" (500 x 1000 mm)	0.31" x 5.12" (8 x 130 mm)	23" x 43" (580 x 1080 mm)	24 x Ø 10.5 mm	40" (997 mm)

Available as EMVDL-RVEX-BS, Rotary valve with explosion detector and control – Available as EMVDL-RV-BS, Rotary valve only

\* Length varies dependent on motor selection – Units in inches rounded to the closest whole number



PRODUCT CODE: 51301

# Explosion Tested Drum Kit

PRODUCT CODES: 51301

## APPLICATIONS

The NFPA compliant Raptor Drum™ Explosion Tested Drum Kit acts as an extension of the dust collector. It is an innovative solution for explosion isolation. No need for wiring, maintenance, motor, starter, wipers, chains.



## DIMENSIONS

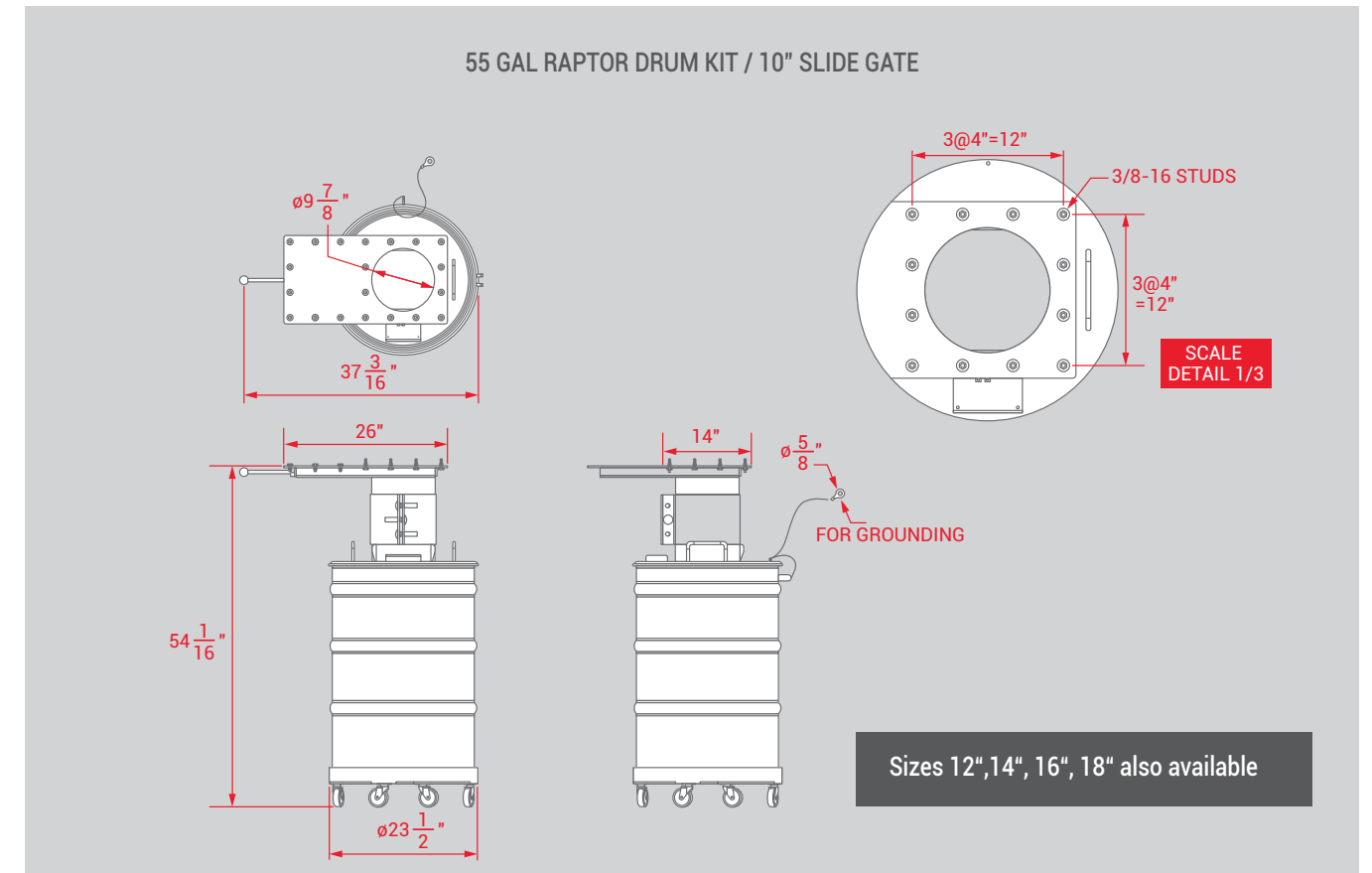

## HOW RAPTOR DRUM WORKS

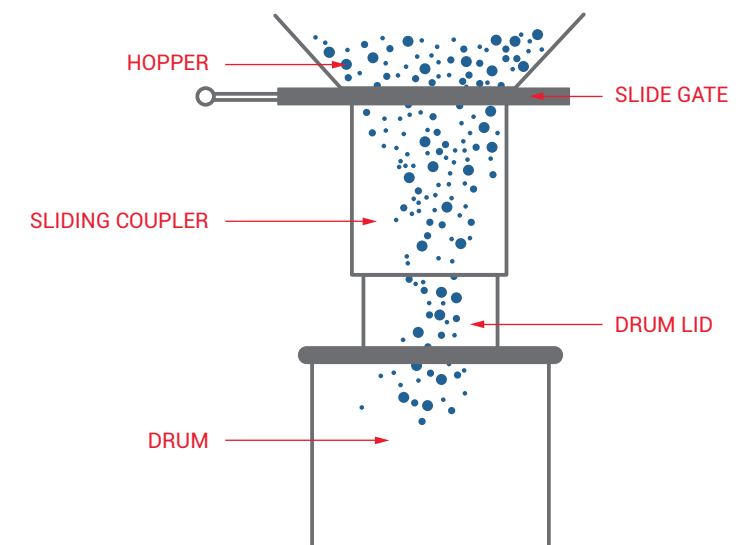

### STANDARD FEATURES

- Standard sizes : 10" -18", 55 gallon or 20 gallon drum

### SIMPLE AND PROVEN

- Explosion Tested to 7psi
- NFPA 69/654 Compliant
- Bonded to a Grounded Collector
- No Moving Parts
- No Flex Hose
- Tool Free





# Flat Explosion Vent Panel EV-VL

Vacuum resistance : 0.7 psi / 20" w.g.

## APPLICATIONS

The Flat Explosion Vent Panel EV-VL is suitable for all applications with low vacuum operating pressures. Typical applications include dust collectors, conveyors, cyclones, elevators, and silos.

The Flat Explosion Vent Panel EV-VL is specifically designed to satisfy low pressure explosion venting requirements. It is designed with an integral gasketed flange that covers the breaking points, ensuring strong mechanical durability. A wide variety of standard and custom sizes and bolt patterns are available.

Standard burst pressure is **1.45 psi / 0.1 bar**. Application specific burst pressures between **1.45 psi up to 7 psi** are available for special orders.



### CERTIFICATIONS & STANDARDS

Ex II GD  
 EN 14491 - EN 14994 - EN 14797 - EN 1127.1  
 EU Certificate : INERIS 15ATEX0001X  
 NFPA 68 - NFPA 69  
 EN 16447  
 Production quality assurance notification :  
 INERIS 08ATEXQ406



### STANDARD FEATURES

- Single Flat Panel 304 stainless steel
- Full frame black EPDM gasket -40°F +176°F (-40°C +80°C)
- Integral 304L stainless steel flange

### OPTIONAL FEATURES

- Stainless steel 316L construction
- Full frame white silicone FDA gasket -76°F +392°F (-60°C +200 °C)
- High temperature graphite gasket -328°F +932°F (-200°C +500°C)
- Integral 316L stainless steel flange with gasket

### ACCESSORIES FOR EV-VL

- Burst Sensor
- Thermal insulation
- Weather protection
- Duct discharge compatible
- Vacuum safety grid

## DIMENSIONS

INTERNAL DIMENSION		EXTERNAL DIMENSION		AREA	
Inches	mm.	Inches	mm.	ft²	m²
4 x 11	110 x 290	7 x 14	174 x 354	0.312	0.029
6 x 24	150 x 600	9 x 27	230 x 680	0.953	0.088
* 7 x 19	170 x 470	10 x 22	250 x 550	0.845	0.078
9 x 17	220 x 420	12 x 20	300 x 500	0.979	0.091
9 x 9	229 x 229	12 x 12	310 x 310	0.554	0.051
9 x 12	229 x 305	12 x 15	310 x 386	0.743	0.069
10 x 24	247 x 610	13 x 27	327 x 690	1.598	0.148
* 11 x 18	270 x 458	14 x 21	350 x 538	1.313	0.122
* 12 x 20	300 x 500	15 x 23	380 x 580	1.593	0.148
12 x 24	300 x 600	14 x 26	366 x 666	1.727	0.160
* 12 x 18	305 x 457	15 x 21	386 x 538	1.491	0.138
* 12 x 24	305 x 610	15 x 27	386 x 690	1.986	0.184
12 x 30	319 x 765	16 x 33	405 x 850	2.669	0.248
13 x 15	340 x 385	16 x 18	404 x 449	1.345	0.125
13 x 17	340 x 440	16 x 20	404 x 504	1.539	0.143
14 x 26	350 x 650	17 x 29	430 x 730	2.427	0.225
15 x 25	375 x 655	18 x 29	460 x 740	2.632	0.244
15 x 24	390 x 620	19 x 28	470 x 700	2.578	0.239
16 x 16	410 x 410	19 x 19	480 x 480	1.787	0.166
16 x 20	420 x 520	20 x 20	500 x 600	2.330	0.216
16 x 36	420 x 920	20 x 39	500 x 1000	4.128	0.383
* 18 x 35	457 x 890	21 x 38	537 x 970	4.348	0.404
18 x 24	470 x 610	22 x 27	550 x 690	3.062	0.284
19 x 27	480 x 680	23 x 31	580 x 780	3.509	0.326
19 x 19	490 x 490	22 x 22	570 x 570	2.562	0.238
* 19 x 23	490 x 590	22 x 26	570 x 670	3.084	0.286

INTERNAL DIMENSION		EXTERNAL DIMENSION		AREA	
Inches	mm.	Inches	mm.	ft²	m²
20 x 20	520 x 520	24 x 24	600 x 600	2.884	0.268
20 x 24	520 x 620	24 x 28	600 x 700	3.444	0.320
20 x 40	520 x 1020	24 x 39	600 x 1000	5.672	0.527
23 x 46	580 x 1180	26 x 50	670 x 1270	7.324	0.680
* 23 x 36	586 x 920	26 x 39	666 x 1000	5.769	0.536
* 24 x 24	610 x 610	27 x 27	690 x 690	3.977	0.369
24 x 36	610 x 920	27 x 39	690 x 1000	6.230	0.561
24 x 44	610 x 1118	27 x 47	690 x 1198	7.303	0.678
25 x 25	645 x 645	29 x 29	740 x 740	4.445	0.413
25 x 44	645 x 1130	29 x 48	735 x 1220	7.803	0.725
26 x 26	653 x 653	29 x 29	740 x 740	4.585	0.426
27 x 27	680 x 680	31 x 31	780 x 780	4.946	0.459
28 x 40	720 x 1020	31 x 43	800 x 1100	7.857	0.730
30 x 31	780 x 780	35 x 35	880 x 880	6.544	0.608
30 x 46	780 x 1180	35 x 50	880 x 1280	9.859	0.916
31 x 40	800 x 1000	35 x 43	890 x 1090	8.567	0.796
35 x 35	880 x 880	39 x 39	980 x 980	8.287	0.770
* 36 x 44	915 x 1118	39 x 47	996 x 1198	10.978	1.020
* 36 x 36	920 x 920	39 x 39	1000 x 1000	9.068	0.842
39 x 39	980 x 980	43 x 43	1080 x 1080	10.332	0.960
40 x 40	1000 x 1000	42 x 42	1056 x 1056	10.418	0.968
* 40 x 40	1020 x 1020	43 x 43	1100 x 1100	11.150	1.036
42 x 42	1080 x 1080	46 x 46	1180 x 1180	12.485	1.160
* 44 x 44	1130 x 1130	48 x 48	1220 x 1220	13.690	1.272
46 x 46	1180 x 1180	50 x 50	1280 x 1280	14.934	1.387
* 40 x 79	1000 x 2000	43 x 82	1080 x 2080	21.461	1.994

Sizes are accurate in mm and rounded to the closest whole number in inches  
 \* Sizes permanently in stock Other sizes available

## ROUND DIMENSIONS

INTERNAL DIMENSION		EXTERNAL DIMENSION		AREA	
Inches	mm.	Inches	mm.	ft²	m²
8	Ø 200	11	Ø 268	0.334	0.031
10	Ø 250	13	Ø 341	0.517	0.048
12	Ø 300	15	Ø 390	0.748	0.069
14	Ø 350	17	Ø 424	1.001	0.093
16	Ø 400	19	Ø 473	1.324	0.123
18	Ø 450	21	Ø 545	1.701	0.158
20	Ø 500	23	Ø 574	2.083	0.193

INTERNAL DIMENSION		EXTERNAL DIMENSION		AREA	
Inches	mm.	Inches	mm.	ft²	m²
* 24	Ø 610	27	Ø 676	3.003	0.279
28	Ø 700	31	Ø 790	4.122	0.383
* 30	Ø 762	33	Ø 842	4.736	0.440
31	Ø 800	35	Ø 880	5.381	0.500
* 36	Ø 914	39	Ø 990	7.065	0.656
39	Ø 990	42	Ø 1070	8.290	0.770

Sizes are accurate in mm and rounded to the closest whole number in inches  
 \* Sizes permanently in stock Other sizes available

Custom sizes and shapes available



# Domed Explosion Vent Panel EV-VD

Vacuum resistance : 3 psi / 83" w.g.

## APPLICATIONS

The **Domed Explosion Vent Panel EV-VD** is specifically designed for high negative pressure applications and installations where high psi pulse cleaning mechanisms could cause metal fatigue over time. The dome design is optimal for Hi-Vac filter systems where explosion relief venting is required. Typical applications included dust collector filters, cyclones, and high pressure vessels.

The **Domed Explosion Vent Panel EV-VD** is pressure tested and certified in compliance with a variety of test standards. It is ideal for **OEM** and retrofit applications. It is easy to install with premium gaskets and integral flanges.

Standard burst pressure is **1.45 psi / 0.1 bar**. Application specific burst pressures between **1.45 psi up to 7 psi** are available for special orders.



### CERTIFICATIONS & STANDARDS

Ex II GD  
 EN 14491 - EN 14994 - EN 14797 - EN 1127.1  
 EU Certificate : INERIS 15ATEX0001X  
 NFPA 68 - NFPA 69  
 Production quality assurance notification :  
 INERIS 08ATEXQ406



### STANDARD FEATURES

- Single domed **304 stainless steel**
- Full frame Gasket, **black EPDM rated -40 F+176 F (-40 C+80 C)**
- Integral 304L stainless steel flange with gasket**

### OPTIONAL FEATURES

- Stainless steel 316L construction**
- Full frame **white silicone FDA gasket -76 F+392 F (-60 C+200 C)**
- High temperature graphite gasket -328 F+932 F (-200 C+500 C)**
- Integral 316L stainless steel flange with gasket**

### ACCESSORIES FOR EV-VD

- Burst Sensor
- Thermal insulation
- Weather protection
- Duct discharge compatible
- Vacuum safety grid

## DIMENSIONS

INTERNAL DIMENSION		EXTERNAL DIMENSION		AREA		INTERNAL DIMENSION		EXTERNAL DIMENSION		AREA	
Inches	mm.	Inches	mm.	ft <sup>2</sup>	m <sup>2</sup>	Inches	mm.	Inches	mm.	ft <sup>2</sup>	m <sup>2</sup>
6 x 24	150 x 600	9 X 27	230 x 680	0.953	0.088	18 x 24	470 x 610	22 X 27	550 x 690	3.062	0.284
* 7 x 19	170 x 470	10 x 22	250 x 550	0.845	0.078	18 x 35	470 x 880	22 x 39	550 x 1000	4.595	0.413
8 x 11	205 x 290	11 X 15	285 x 370	0.624	0.058	19 x 19	490 x 490	22 X 22	570 x 570	2.562	0.238
9 x 17	220 x 420	12 X 20	300 x 500	0.979	0.091	* 19 x 23	490 x 590	22 X 26	570 x 670	3.084	0.287
9 x 9	229 x 229	12 X 12	310 x 310	0.554	0.051	21 x 26	525 x 668	25 X 30	630 x 765	3.659	0.340
9 x 12	229 x 305	12 X 15	310 x 386	0.743	0.069	* 23 x 36	586 x 920	26 X 39	666 x 1000	5.770	0.536
10 x 24	247 x 610	13 X 27	327 x 690	1.598	0.148	* 24 x 24	610 x 610	27 X 27	690 x 690	3.977	0.370
* 11 x 18	270 x 458	14 X 21	350 x 538	1.313	0.122	24 x 36	610 x 920	27 x 30	690 x 765	6.040	0.561
* 12 x 20	300 x 500	15 X 23	380 x 580	1.593	0.148	24 x 44	610 x 1118	27 X 47	690 x 1198	7.303	0.678
* 12 x 18	305 x 457	15 X 21	386 x 538	1.491	0.138	25 x 25	645 x 645	29 X 29	735 x 735	4.445	0.413
* 12 x 24	305 x 610	15 X 27	386 x 690	1.986	0.185	25 x 44	645 x 1130	29 X 48	735 x 1220	12.547	0.413
13 x 15	340 x 385	16 X 18	404 x 449	1.345	0.125	26 x 26	653 x 653	29 X 29	740 x 740	4.585	0.426
13 x 17	340 x 440	16 X 20	404 x 504	1.539	0.143	* 36 x 44	915 x 1118	39 X 47	996 x 1198	10.978	1.020
* 14 x 26	350 x 650	17 X 29	430 x 730	2.427	0.226	* 36 x 36	920 x 920	39 X 39	1000 x 1000	9.068	1.842
15 x 26	375 x 655	18 X 29	460 x 740	2.632	0.244	36 x 54	920 x 1380	39 X 57	1000 x 1460	13.368	1.242
16 x 16	410 x 410	19 X 19	480 x 480	1.787	0.166	39 x 39	980 x 980	43 X 43	1080 x 1080	10.332	1.960
20 x 28	457 x 890	21 X 38	537 x 970	4.348	0.404	40 x 40	1020 x 1020	43 X 43	1100 x 1100	11.150	1.036

Sizes are accurate in mm and rounded to the closest whole number in inches  
 \* Sizes permanently in stock Other sizes available

## ROUND DIMENSIONS

INTERNAL DIMENSION		EXTERNAL DIMENSION		AREA		INTERNAL DIMENSION		EXTERNAL DIMENSION		AREA	
Inches	mm.	Inches	mm.	ft <sup>2</sup>	m <sup>2</sup>	Inches	mm.	Inches	mm.	ft <sup>2</sup>	m <sup>2</sup>
8	Ø 200	11	Ø 268	0.334	0.031	* 24	Ø 610	27	Ø 676	3.003	0.279
10	Ø 250	13	Ø 341	0.517	0.048	28	Ø 700	31	Ø 790	4.122	0.383
12	Ø 300	15	Ø 390	0.748	0.069	* 30	Ø 762	33	Ø 842	4.736	0.440
14	Ø 350	17	Ø 424	1.001	0.093	31	Ø 800	35	Ø 880	5.381	0.500
16	Ø 400	19	Ø 473	1.324	0.123	* 36	Ø 914	39	Ø 990	7.065	0.656
18	Ø 450	21	Ø 545	1.701	0.158	39	Ø 990	42	Ø 1070	8.290	0.770
20	Ø 500	23	Ø 574	2.083	0.193						

Sizes are accurate in mm and rounded to the closest whole number in inches  
 \* Sizes permanently in stock Other sizes available

Custom sizes and shapes available





# Sanitary Flat Explosion Vent Panel EV-VLSAN

Vacuum resistance : 0.7 psi / 20" w.g.

## APPLICATIONS

The **Sanitary Flat Explosion Vent Panel EV-VLSAN** is designed specifically for hygienic applications in food and pharmaceutical industries. Dedicated to protect systems with low vacuum or working pressure (**up to 50 % of static burst pressure**) such as spray dryers.

The high technology design of this vent panel avoids contaminants.

The standard burst pressure is **0.1 bar (max. 0.5 bar)** at **22 °C (72 °F)**.



## DIMENSIONS

INTERNAL DIMENSION		EXTERNAL DIMENSION		AREA	
Inches	mm.	Inches	mm.	ft²	m²
24 x 24	610 x 610	27 X 27	690 x 690	3.977	0.370
23 x 36	586 x 920	26 X 39	666 x 1000	5.770	0.536
31 x 35	780 x 880	39 X 35	990 x 890	5.770	0.536
36 x 36	920 x 920	39 X 39	1000 x 1000	9.068	1.842
40 x 40	1020 x 1020	43 X 43	1100 x 1100	11.150	1.036

Sizes are accurate in mm and rounded to the closest whole number in inches

\* Sizes permanently in stock

Other sizes available

### CERTIFICATIONS & STANDARDS

Ex II GD  
 EN 14491 - EN 14994 - EN 14797 - EN 1127.1  
 EU Certificate : INERIS 15ATEX0001X  
 EHEDG Certificate : C1900020  
 Production quality assurance notification :  
 INERIS 08ATEXQ406



### STANDARD FEATURES

- Single flat 316 stainless steel
- Full frame Gasket, **black EPDM** rated +14 F+482 F (-10 C+250 C)  
 - FDA  
 - 1935/2004CE
- Integral 304L stainless steel flange
- Clean design
- Bacteriological barrier

### ACCESSORIES FOR EV-VL-SANITARY

- Burst Sensor
- Weather protection
- Duct discharge compatible



# High Vacuum Domed Explosion Vent Panel EV-VD-HV

Vacuum resistance : 3-9 psi / 83-250" w.g.

## APPLICATIONS

The High Vacuum Domed Explosion Vent Panel EV-VD-HV is specifically engineered to be an ideal solution for applications where negative operating pressures exceed **3 psi** or operational metal fatigue is anticipated. Some high energy pulse-jet filter cleaning mechanisms, and systems operating under extreme high pressure, have been known to significantly shorten the life of standard explosion panels.

The High Vacuum Domed Explosion Vent Panel EV-VD-HV is pressure tested and certified under a variety of test standards. It is ideal for OEM and retrofit extreme duty applications. It is easy to install with premium gaskets and integral flanges.

Standard burst pressure is **1.45 psi / 0.1 bar**. Application specific burst pressures between **1.45 psi up to 7 psi** are available for special orders.



### CERTIFICATIONS & STANDARDS

Ex II GD  
 EN 14491 - EN 14994 - EN 14797 - EN 1127.1  
 EU Certificate : INERIS 15ATEX0001X  
 NFPA 68 - NFPA 69  
 Production quality assurance notification :  
 INERIS 08ATEXQ406



### STANDARD FEATURES

- Mechanically Reinforced single dome 304L stainless steel
- Full frame Gasket, **black EPDM rated -40°F+176°F (-40°C +80°C)**
- Integral 304L stainless steel flange

### OPTIONAL FEATURES

- Stainless steel 316L construction
- Full frame **white silicone FDA gasket -76°F +392°F (-60°C +200°C)**
- High temperature graphite gasket **-328°F +932°F (-200°C +500°C)**
- Integral 316L stainless steel flange with gasket

### ACCESSORIES FOR EV-VD HV

- Burst Sensor
- Thermal insulation
- Weather protection
- Duct discharge compatible
- Vacuum safety grid

## DIMENSIONS : RECTANGULAR & SQUARE

INTERNAL DIMENSION		EXTERNAL DIMENSION		AREA		INTERNAL DIMENSION		EXTERNAL DIMENSION		AREA	
Inches	mm.	Inches	mm.	ft <sup>2</sup>	m <sup>2</sup>	Inches	mm.	Inches	mm.	ft <sup>2</sup>	m <sup>2</sup>
6 x 24	150 x 600	9 X 27	230 x 680	0.953	0.088	15 x 26	375 x 655	18 X 29	460 x 740	2.632	0.244
* 7 x 19	170 x 470	10 x 22	250 x 550	0.845	0.078	16 x 16	410 x 410	19 X 19	480 x 480	1.787	0.166
8 x 11	205 x 290	11 X 15	285 x 370	0.624	0.058	20 x 28	457 x 890	21 X 38	537 x 970	4.348	0.404
9 x 17	220 x 420	12 X 20	300 x 500	0.979	0.091	18 x 24	470 x 610	22 X 27	550 x 690	3.062	0.284
9 x 9	229 x 229	12 X 12	310 x 310	0.554	0.051	19 x 19	490 x 490	22 X 22	570 x 570	2.562	0.238
9 x 12	229 x 305	12 X 15	310 x 386	0.743	0.069	* 19 x 23	490 x 590	22 X 26	570 x 670	3.084	0.287
10 x 24	247 x 610	13 X 27	327 x 690	1.598	0.148	21 x 26	525 x 668	25 X 30	630 x 765	3.659	0.340
* 11 x 18	270 x 458	14 X 21	350 x 538	1.313	0.122	* 23 x 36	586 x 920	26 X 39	666 x 1000	5.770	0.536
* 12 x 20	300 x 500	15 X 23	380 x 580	1.593	0.148	* 24 x 24	610 x 610	27 X 27	690 x 690	3.977	0.370
12 x 18	305 x 457	15 X 21	386 x 538	1.491	0.138	24 x 44	610 x 1118	27 X 47	690 x 1198	7.303	0.678
* 12 x 24	305 x 610	15 X 27	386 x 690	1.986	0.185	25 x 25	645 x 645	29 X 29	735 x 735	4.445	0.413
13 x 15	340 x 385	16 X 18	404 x 449	1.345	0.125	25 x 44	645 x 1130	29 X 48	735 x 1220	12.547	0.413
13 x 17	340 x 440	16 X 20	404 x 504	1,539	0.143	26 x 26	653 x 653	29 X 29	740 x 740	4.585	0.426
* 14 x 26	350 x 650	17 X 29	430 x 730	2.427	0.226						

Sizes are accurate in mm and rounded to the closest whole number in inches  
 \* Sizes permanently in stock Other sizes available

## DIMENSIONS : ROUND

INTERNAL DIMENSION		EXTERNAL DIMENSION		AREA		INTERNAL DIMENSION		EXTERNAL DIMENSION		AREA	
Inches	mm.	Inches	mm.	ft <sup>2</sup>	m <sup>2</sup>	Inches	mm.	Inches	mm.	ft <sup>2</sup>	m <sup>2</sup>
8	Ø 200	11	Ø 268	0.334	0.031	24	Ø 600	27	Ø 676	3.003	0.279
10	Ø 250	13	Ø 341	0.517	0.048	28	Ø 700	31	Ø 790	4.122	0.383
12	Ø 300	15	Ø 390	0.748	0.069	30	Ø 750	33	Ø 842	4.736	0.440
14	Ø 350	17	Ø 424	1.001	0.093	31	Ø 800	35	Ø 880	5.381	0.500
16	Ø 400	19	Ø 473	1.324	0.123	36	Ø 914	39	Ø 990	7.065	0.656
18	Ø 450	21	Ø 545	1.701	0.158	39	Ø 990	42	Ø 1070	8.290	0.770
20	Ø 500	23	Ø 574	2.083	0.193						

Sizes are accurate in mm and rounded to the closest whole number in inches  
 Other sizes available

Custom sizes and shapes available

# Explosion Vent Deflector EV-VS VIGISPACE

## APPLICATIONS

When an outdoor explosion occurs, explosion vents open and release the explosion flame and pressure wave into the environment.

The Explosion Vent Deflector EV-VS VIGISPACE limits the opening angle of the explosion vent and guides the explosion pressure wave, flames and heat into defined areas.

By decreasing the size of dangerous areas, the VIGISPACE helps to reduce the safety zone to a minimum and increases usable operating space while providing optimum protection against explosions.



### CERTIFICATIONS & STANDARDS

Ex II GD  
 EN 14491 - EN 14797 - EN 1127.1  
 Production quality assurance notification :  
 INERIS 08ATEXQ406  
 NFPA & ATEX Certified



### STANDARD FEATURES

- Steel construction with safety red finish
- For use with EV-VL/VLSIL and EV-VD/VDSIL
- 80% efficient

### OPTIONAL FEATURES

- Stainless steel material 304L

## APPLICATIONS



Explosion without VIGISPACE

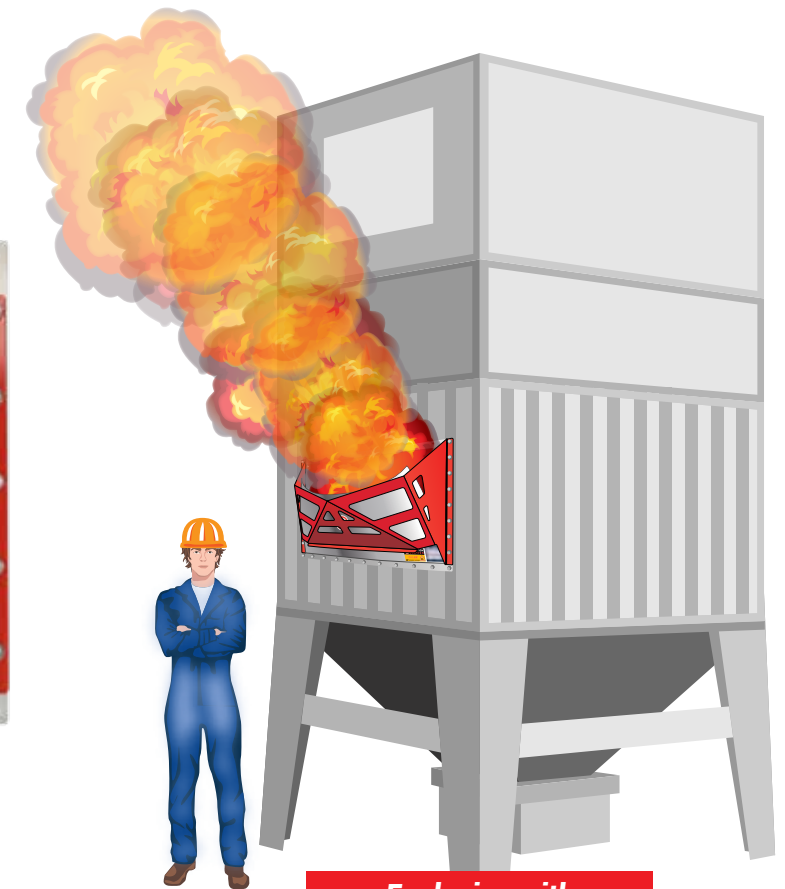

Explosion with VIGISPACE

### TECHNICAL INFORMATION

KST max : 200 bar m/s, Pmax: 12 bar max, Pred max, 0.5 bar, Pstat max, 0.1 bar



# Flameless Explosion Vent EV-VQ

## APPLICATIONS

The **Flameless Explosion Vent EV-VQ** is a rectangular explosion device that combines a standard explosion panel with added protection to prevent flame from entering the environment.

The **Flameless Explosion Vent EV-VQ** is certified for indoor and outdoor applications. It eliminates the need for costly heavy duty piping that is required for exterior venting when a vessel is installed within the workspace. The integral standard **Explosion Vent Panel** bursts during the initial explosion phase. Immediately thereafter, the flame and burnt dust exit the vessel and is contained by the **EV-VQ** flame arrestor.

All **Flameless Explosion Vents** are designed with the ability to replace the explosion panel without removing the flame arrestor assembly.

**Boss Products®** technical engineering staff is dedicated to ensuring optimum design & product selection for every application.



## DIMENSIONS

EV-VQ SPECIFICATIONS								
ECOMAXX® VIGILEX VQ			IN COMBINATION WITH VENT PANEL				BOLT SPECS	
	in[mm]		Nominal Size in[mm]		Nominal Square ft²[m²]		Qty	Size
VQ	7 x 19	[170 x 470]	7 x 19	[170 x 470]	0.845	[0.0785]	20	M10 x 30
VQ	11 x 18	[270 x 458]	11 x 18	[270 x 458]	1.315	[0.1220]	22	M10 x 30
VQ	12 x 20	[300 x 500]	12 x 20	[300 x 500]	1.595	[0.1480]	24	M10 x 30
VQ	12 x 24	[305 x 610]	12 x 24	[305 x 610]	1.980	[0.1840]	26	M10 x 30
VQ	14 x 26	[350 x 650]	14 x 26	[350 x 650]	2.425	[0.2250]	26	M10 x 30
VQ	19 x 23	[490 x 590]	19 x 23	[490 x 590]	3.084	[0.2865]	32	M10 x 30
VQ	24 x 24	[610 x 610]	24 x 24	[610 x 610]	3.975	[0.3695]	32	M10 x 30
VQ	18 x 35	[457 x 890]	18 x 35	[457 x 890]	4.349	[0.4040]	34	M10 x 30
VQ	23 x 36	[586 x 920]	23 x 36	[586 x 920]	5.770	[0.5360]	42	M10 x 30
VQ	25 x 44	[645 x 1130]	25 x 44	[645 x 1130]	7.804	[0.7250]	34	M10 x 30
VQ	36 x 36	[920 x 920]	36 x 36	[920 x 920]	9.068	[0.8425]	50	M10 x 30
VQ	44 x 44	[1130 x 1130]	44 x 44	[1130 x 1130]	13.696	[1.2720]	58	M10 x 30

## ADVANTAGES

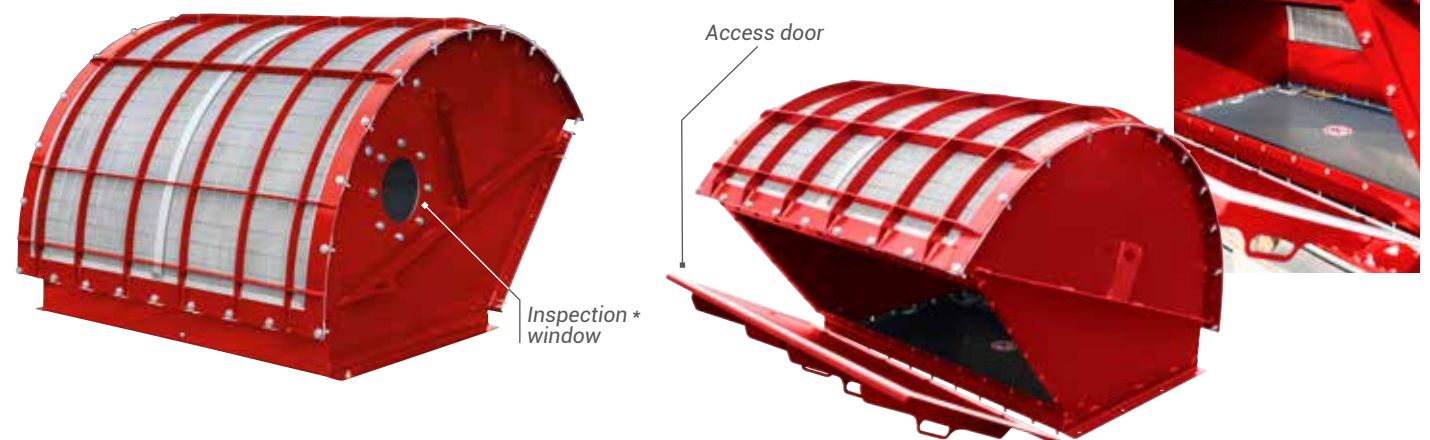

## TECHNICAL INFORMATION

EV-VQ	$K_{st} \max = 500$	$P_{max} \leq 145 \text{ psi} / 10 \text{ bar}$	$P_{red} \leq 7 \text{ psi} / 0.5 \text{ bar}$	$P_{stat} = 1.45 \text{ to } 3 \text{ psi} / 0.1 \text{ to } 0.5 \text{ bar}$
-------	---------------------	---	--	---

\*  $P_{red} < 1.85$  for VQ 920x920 and 1130x1130

### CERTIFICATIONS & STANDARDS

Ex II GD - Ex II 2 D  
 EC Certificate : INERIS 14 ATEX 0049 X  
 NFPA 68 - NFPA 69  
 Production quality assurance notification :  
 INERIS 08ATEXQ406

- certified for :
- Organic dust
  - Fiber dust
  - Gas



### STANDARD FEATURES

- Mild steel construction epoxy coated red
- Stainless steel mesh

### OPTIONAL FEATURES

- Silicone gasket
- UL 698A Intrinsic control panel
- All stainless steel construction
- Dust cover



# Curved Flameless Explosion Vent EV-VQ R

## APPLICATIONS

The **Curved Flameless Explosion Vent EV-VQ R** is similar to the standard **EV-VQ**, but is available with an application specific curved flange to accommodate mounting on cylindrical vessels, without the need for expensive flange adapters. This design feature reduces accumulation of dust/material in a fabricated transition in front of the flameless vent's integral explosion panel.

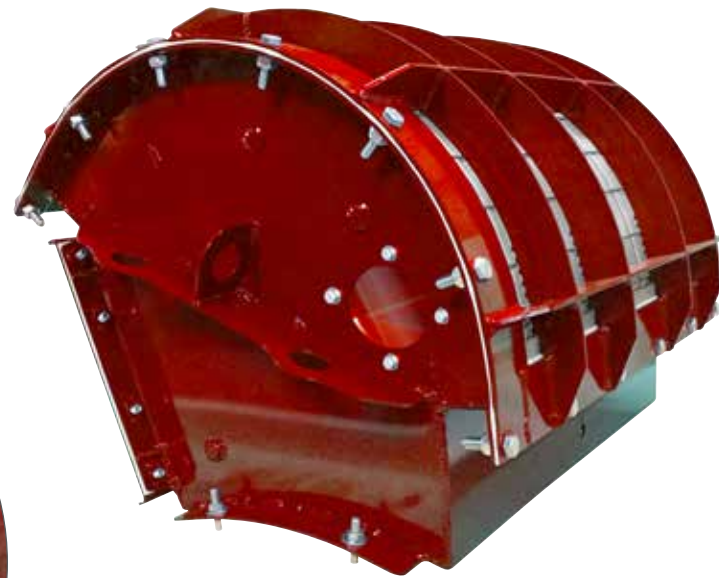
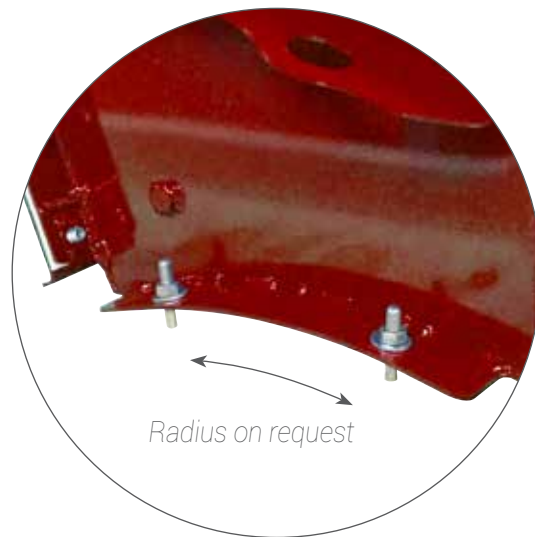

### STANDARD FEATURES

- R Style Vent Panel with EPDM gasket
- Mild steel construction epoxy coated red.
- Stainless steel mesh flame arrestor
- Burst sensor
- Mounting radius per design application

### OPTIONAL FEATURES

- Silicone gasket
- All stainless steel construction
- UL 698A Intrinsic control panel
- Dust cover

Dust cover



## FLAMELESS STAINLESS STEEL EV-VQ

The **Flameless Stainless Steel EV-VQ** is a rectangular flameless device with a standard VIGILEX bursting panel. It is a perfect option for food or pharmaceutical facilities or high moisture atmospheres.

The **Flameless Stainless Steel EV-VQ** provides effective low pressure resistance, eliminating the spread of flame and glowing particles.

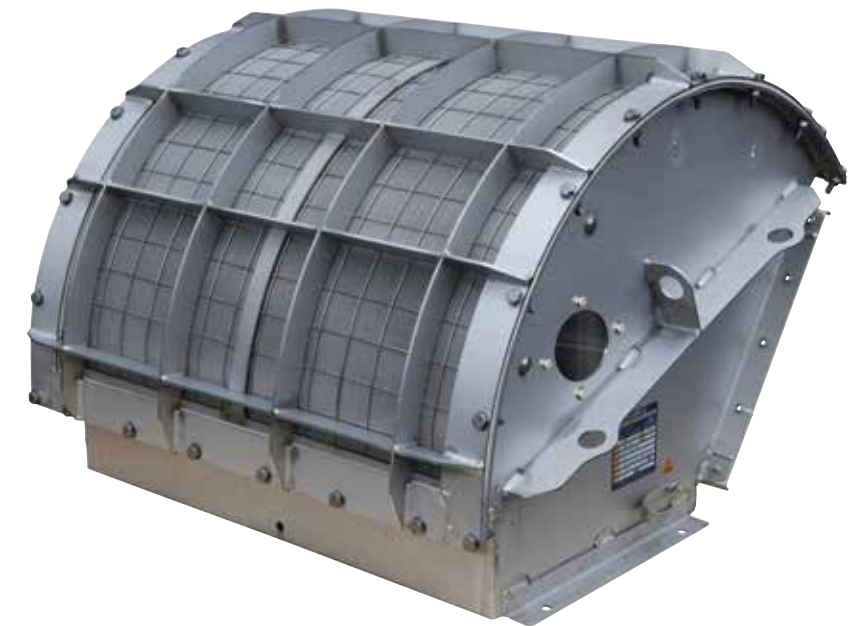

### STANDARD FEATURES

- R Style Vent Panel with EPDM gasket
- Mild steel construction epoxy coated red.
- Stainless steel mesh flame arrestor
- Burst sensor
- Mounting radius per design application

### OPTIONAL FEATURES

- Dust cover





PRODUCT CODES: 56501, 56502, 56503 & 56504



PRODUCT CODES: 56501, 56502, 56503 & 56504

# Spark Detection and Extinguishing System

## APPLICATIONS

The Raptor Spark™ Detection and Extinguishing System is an FM APPROVED safety device that is designed to detect and extinguish sparks and glowing embers that are traveling through a duct system. The hazard is detected by infrared sensors and extinguished with water spray nozzles within milliseconds of detection.

The Raptor Spark™ Detection control module has the capacity to receive hazard alert signals from multiple components (Dust Probes & Thermal Probes) and monitor multiple duct-zones and vessels. The Raptor Spark™ Detection and Extinguishing System is an essential Fire Protection, Fire Isolation and Diversion device that

is commonly installed with EcoMAXX® High Speed Abort Gates, FireBreak Shutters, EcoMAXX®/VigilEX Explosion Vents and explosion certified EcoMAXX®/

VDL Rotary Valves. Typical automatic functions include hazard detection, system shut-down, isolation/abort, and extinguish and/or suppression.

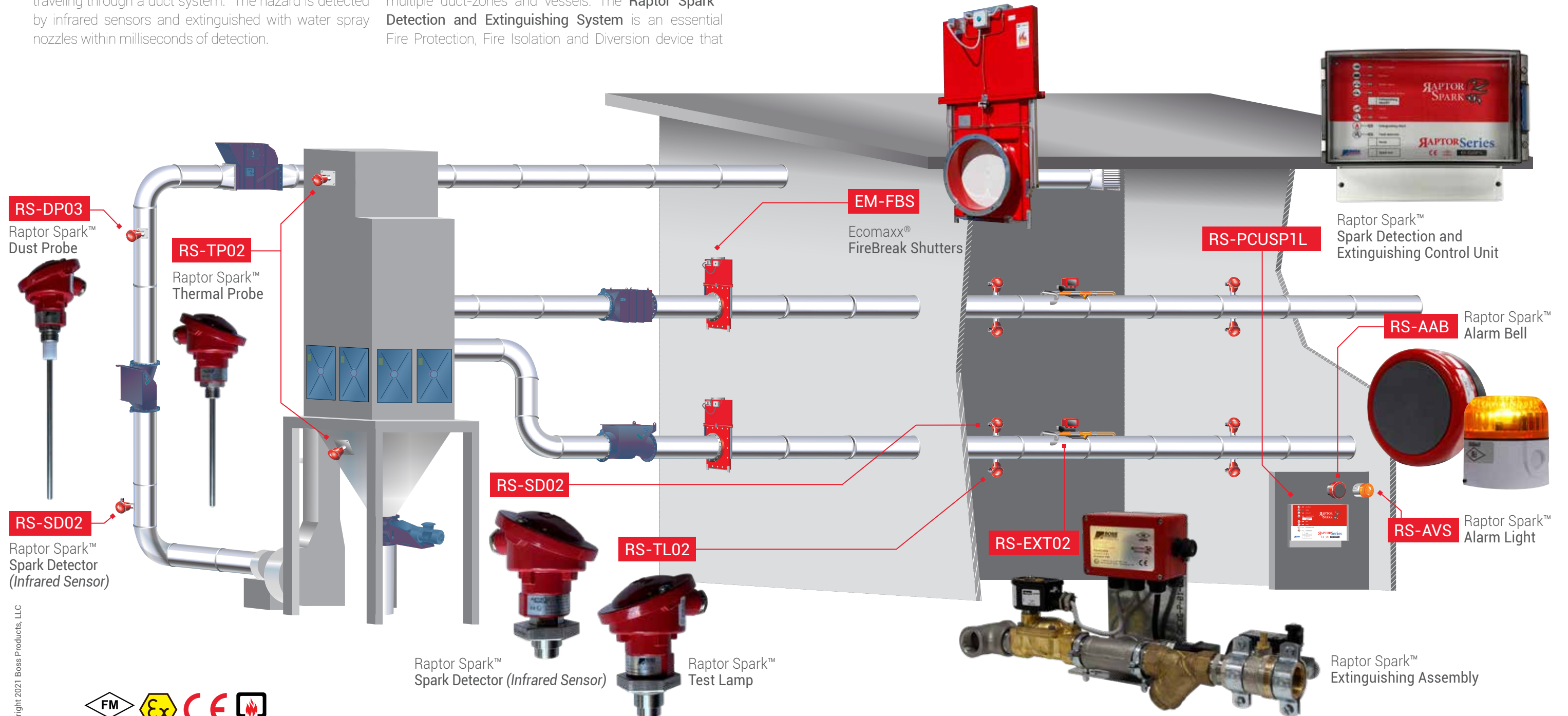

copyright 2021 Boss Products, LLC



copyright 2021 Boss Products, LLC





# Spark Detection and Extinguishing System

## APPLICATIONS

### Raptor Spark™ Detection & Extinguishing Control Unit RS-PCUSP1L

The Raptor Spark Detection & Extinguishing Control Unit (RS-PCUSP1L) is designed to minimize the risk of fire and explosion in dust filtration and pneumatic conveying systems. This control unit communicates with a variety of components to monitor and protect up to six individual zones. The Control Unit (RS-PCU1610SD) is FM Approved.



### Raptor Spark™ Extinguishing Assembly RS-EXT02

The Extinguishing Assembly (RS-EXT02) is designed to work in conjunction with the RS-PCUSP1L control unit and RS-SD02 Spark Detectors. When the control module gets a signal that a hazard has been detected, the extinguishing assembly is activated. A water spray is initiated inside the piping system to extinguish sparks or glowing embers that could cause fire or explosion. The Extinguishing Assembly (RS-EXT02) is FM Approved and ATEX Certified.



### Raptor Spark™ Dust Probe RS-DP03

The Dust Probe (RS-DP03) is a charge displacement probe that uses the principle of the displacement of the electric charge in the electrode. It signals the RS-PCUSP1L Control Unit when there is an increase in the concentration of dust levels which could potentially indicate the rupture or ineffective operation of dust filters and/or dust bags. The Dust Probe (RS-DP03) is FM Approved and ATEX Certified.



### Raptor Spark™ Thermal Probe RS-TP02

The Thermal Probe (RS-TP02) is designed to work either as a thermovelocimetric output (rapid raise in temperature in a short amount of time), or as a thermostatic output (fixed temperature threshold) to alarm the RS-PCUSP1L Control Unit of potential fire hazards in the ductwork, dust collector units, hoppers, cyclones and etc. The Thermal Probe (RS-TP02) is FM Approved and ATEX Certified.

### Raptor Spark™ Spark Detector RS-SD02

The Spark Detector (RS-SD02) is designed to work with the RS-PCUSP1L Control Unit. The Spark Detector uses advanced technology and circuit, sensitive to infrared light to detect sparks, flames, and incandescent material that passes in front of its optical element. The Spark Detector (RS-SD02) is FM Approved and ATEX Certified.



### Raptor Spark™ Test Lamp RS-TL02

The Test Lamp (RS-TL02) is designed to work in association with the Spark Detectors (RS-SD02). The Test Lamp provides a function check to ensure the cleanliness of the Spark Detector lenses by emitting high infrared radiation into ducting or pneumatic conveying lines across from the spark detectors to simulate a spark or glowing ember in the line. The Test Lamp (RS-TL02) is FM Approved and ATEX Certified.



### EcoMAXX® Firebreak Shutter EM-FBS-00

The FireBreak Shutter is engineered to isolate fires and fire hazards in process ventilation and dust collection applications. The Fire Break Shutter can be activated by the EM-FCS-CU1610 Control Unit or RS-PCUSP1L via Spark Detection or sensing activation by Thermal Probe.



## CERTIFICATIONS & STANDARDS

Models P and MA  
ATEX EN 1366-2, EN 13501  
CSI 1643FR, REI 120-RE 120  
CE



## STANDARD FEATURES

- Output for Pre-Alarm
- 4-20mA proportional output
- IP65 Enclosure
- Output for Alarm
- Bus RS485

## OPTIONAL FEATURES

- Magnetic
- Pneumatic
- Fusible Link



## Thermal Probe RS-TP02

### APPLICATIONS

The **Thermal Probe RS-TP02** monitors the temperature rise within a vessel using thermostatic technology. The **Thermal Probe** is complete with an alarm function which signals upon rapid temperature rise based on fixed threshold set points to monitor the temperature in enclosures. It is designed to be used specifically for fire protection in dust collection systems.

The probes are equipped with a **6"/150 mm long steel stylus** that can be placed within the area to be monitored (eg, silos, cyclones, filter units) while the electronic circuit and electrical cable connections remain outside the vessel. These probes have cast aluminum enclosures with IP65 protection. The internal circuit and the measuring sensor (within the stylus) are immersed in a resin bi-component which allows the probe to be installed in difficult places, such as dusty environments. **The Thermal Probe is suitable for ATEX zone 22.**

PRODUCT CODE: 56505

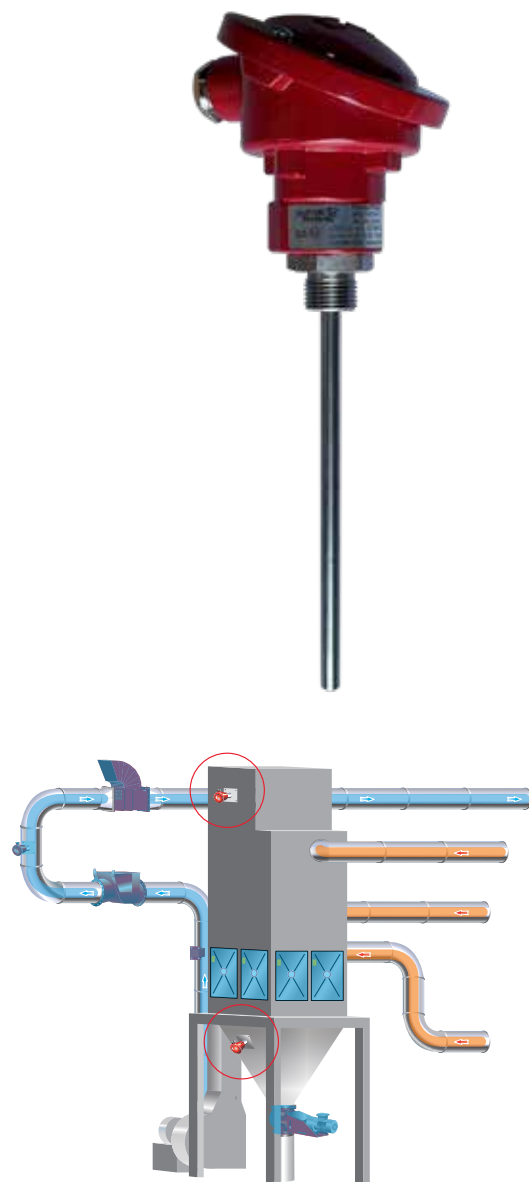

### CERTIFICATIONS & STANDARDS

ATEX Zone 22  
CE  
FM Approved



### STANDARD FEATURES

- Output for Pre-Alarm
- Output for Alarm
- 4-20mA proportional output
- Bus RS485
- IP65 Enclosure



## Dust Probe (Broken Bag Detector) RS-DP03

### APPLICATIONS

The **Dust Probe RS-DP03** is a microprocessor based instrument that is designed to detect and measure dust emissions caused by leaks in filtration media. Design characteristics include pre-calibrated digital optically isolated outputs and a set of **LED indicators**.

PRODUCT CODE: 57502

### OPERATING PRINCIPLE

The **dust probe** uses the principle of the displacement of the electric charge in the electrode, induced by the electrical charges, carried by dust immersed in a gaseous fluid.

The amount of electric charge dynamically induced on the electrode is proportional to the amount of dust present in the gaseous fluid. An increase in the concentration of dust, causes a proportional increase of the signal that reaches the microprocessor.

Applying sophisticated mathematical algorithms, the individual powder particles are counted so as to be able to calculate their concentration.

The computed values can be stored internally in order to be drafted in the future, or sent via **RS485 serial transmission**, or **PWM 4/20 mA** to an **external control unit** for further analysis.

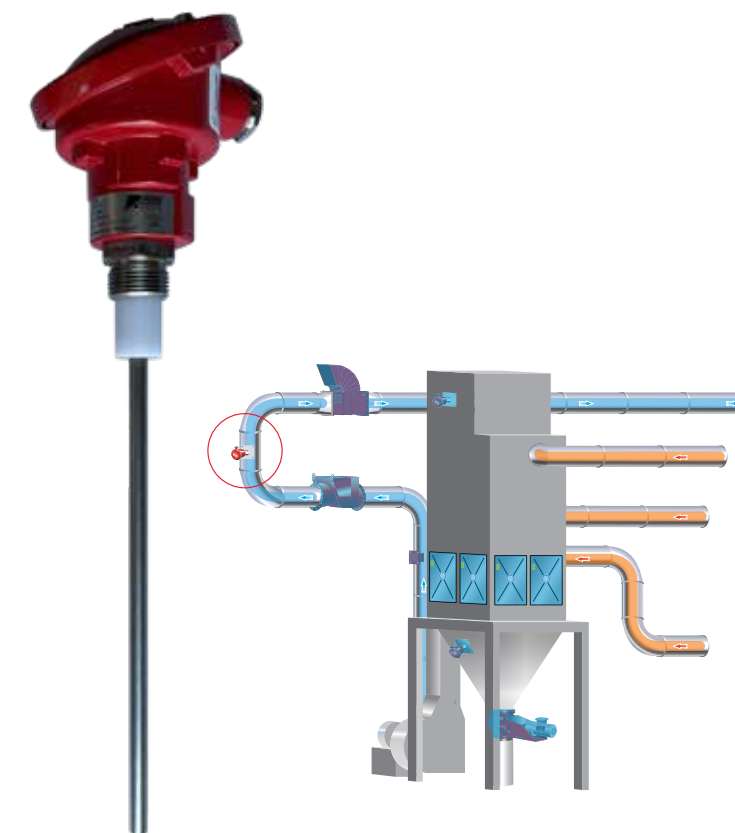

### STANDARD FEATURES

- Electrode length : 10" / 250 mm
- Enclosure dimensions : 3 1/4"x3" x 2 5/16" / 80 x 75 x 58 mm
- Material : stainless steel 5/16" / ø 8 mm
- Sensitivity : 10x10<sup>-8</sup> oz/cu.ft – 0.1 mg/mc
- Outputs : 2 programmable open collector
- Interfaces : 1 serial (RS485)
- Protection : ATEX II 3D EEx IP65 T 185° F / 85° C

CODE	RESOLUTION	SET1	SET2	OUT 4/20mA	END OF SCALE 20mA	AUTOACQUISITION	RS485
57502-020000	10x10 <sup>-8</sup> oz/cu.ft 0,1 mg/m <sup>3</sup>	5x10 <sup>-6</sup> oz/cu.ft 5 mg/m <sup>3</sup>	10x10 <sup>-6</sup> oz/cu.ft 10 mg/m <sup>3</sup>	NO	10x10 <sup>-6</sup> / 5x10 <sup>-5</sup> oz/cu.ft 10/50 mg/m <sup>3</sup>	YES	YES
57502-010000	10x10 <sup>-8</sup> oz/cu.ft 0,1 mg/m <sup>3</sup>	5x10 <sup>-6</sup> oz/cu.ft 5 mg/m <sup>3</sup>	10x10 <sup>-6</sup> oz/cu.ft 10 mg/m <sup>3</sup>	YES	10x10 <sup>-6</sup> / 5x10 <sup>-5</sup> oz/cu.ft 10/50 mg/m <sup>3</sup>	NO	YES



# Water Pressure Booster Pump RS-CPR

## APPLICATIONS

The Raptor Spark™ Water Pressure Booster Pump RS-CPR was designed to regulate water pressure going into the extinguishing unit. It is the best solution for facilities that have over or under pressure water lines available for installation of the Spark Detection and Extinguishing System.



### STANDARD FEATURES

- System comes in an epoxy powder coated steel enclosure and includes :
  - (1) 3/8" water inlet connection with 1-way valve
  - (1) water reservoir tank with level sensor and pressure gauge
  - (1) 1" water outlet connection,
  - (1) 3/8" compressed air inlet connection with 1-way valve (minimum pressure required is 116 PSI / 8 bar), compressed air reservoir tank, air tank pressure switch, regulator, solenoids, and cable grips.

### OPTIONAL FEATURES

- Standard sizes : 15 L, 30 L, 40 L

### ACCESSORIES FOR WATER PRESSURE BOOSTER PUMP RS-CPR

- RS-PWE (Packaged Water Extinguishing Group Assembly Kit)

## PRODUCT'S CATEGORY SUITABLE TO THE INSTALLATION'S ZONE

The distance between the water station must **not exceed 23 ft.**  
The choice of model capacity is based on the number of nozzles.

## COMPONENTS

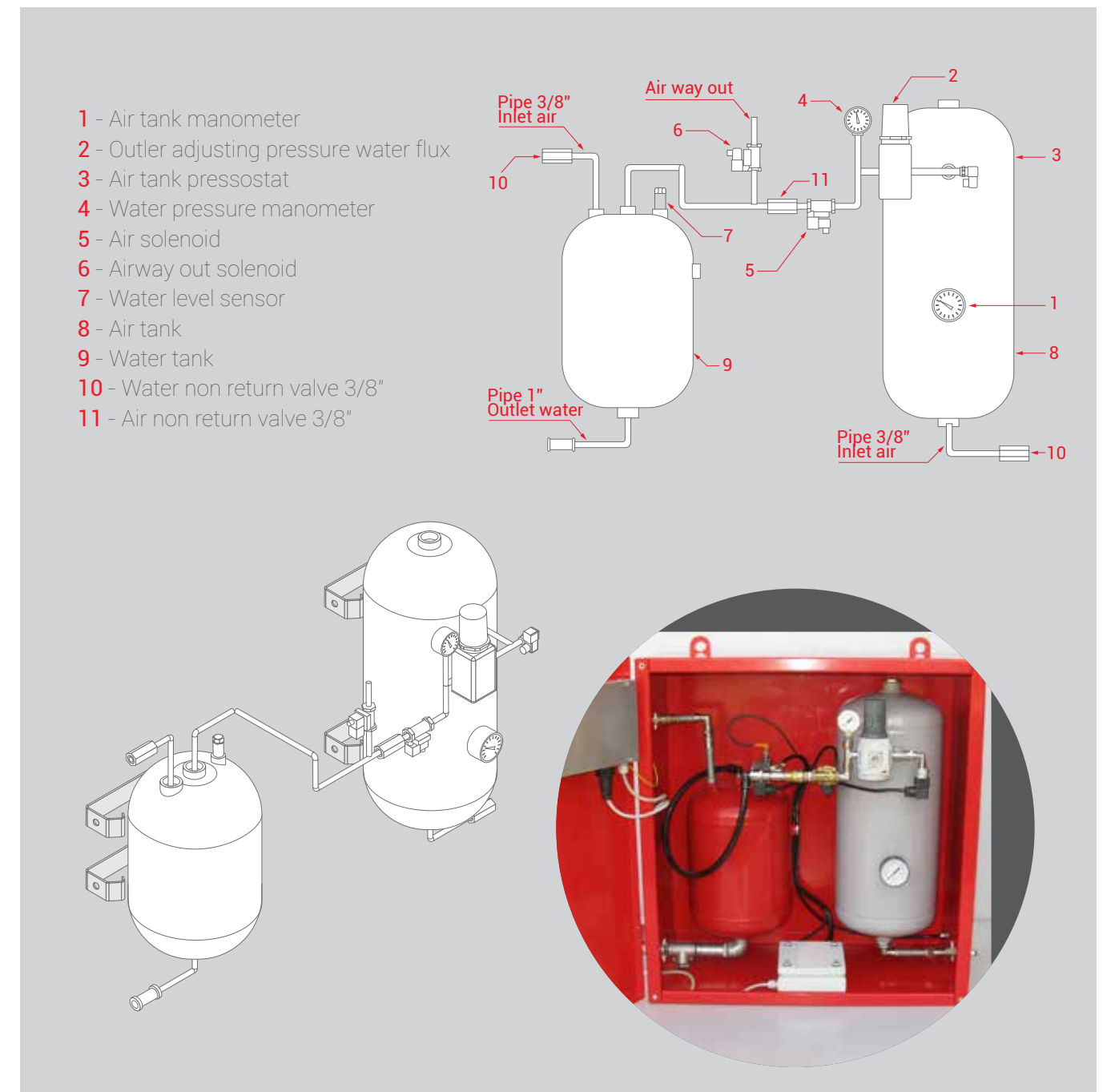



PRODUCT CODE: 51001

# Raptor Shield (Spark Trap)

PRODUCT CODES: 51001

## APPLICATIONS

The Raptor Shield™ (Spark Trap) was designed with maximum cooling technology that ensures maximum reduction in sparks or burning embers. This device has no moving parts for extremely low maintenance. The spark arrestor is designed to be directly connected to any typical duct connection.

The Raptor Shield™ (Spark Trap) is a critical part of fire prevention in a dust collection system. They help block sparks before they can start a fire. They are a very low-maintenance and highly effective method that helps block sparks from getting past.

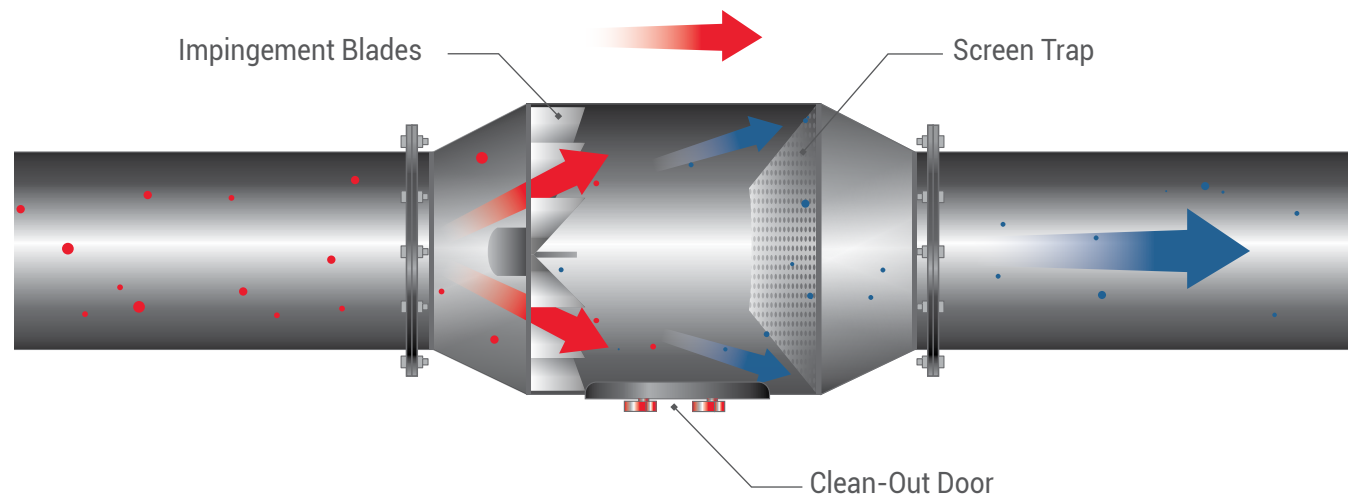

### CERTIFICATIONS & STANDARDS

NFPA Compliant



### STANDARD FEATURES

- Standard sizes : 6" -50" (more on request)
- Heavy duty construction
- Clean-out door
- No maintenance
- Can be installed in horizontal or vertical configuration
- Flanged ends

## APPLICATION AND GUIDELINES

**LOCATION** - One duct diameter between inlet of spark arrestor and spark source. There must be a minimum of **10 duct diameters** between the outlet of the spark arrestor and dust collector or separator.

**FLOW** - Best practice is using the spark arrestor in duct velocities greater than **400 fpm** but not exceeding **5000 fpm**.

**TEMPERATURE** - Performance is dependent upon the conveying velocity being at lower temperature than the spark ember itself. Therefore, it should be used in operations with temperatures below ignition point of the suspended particulates and in no case higher than **200 degrees**.

## PERFORMANCE

The Raptor Shield™ (Spark Trap) is designed and applied as a preventative measure to reduce lifecycle and rate of hazardous sparks within the properly

applied system. The Raptor Shield™ is not designed to extinguish actual fires or stop mitigation of explosion.

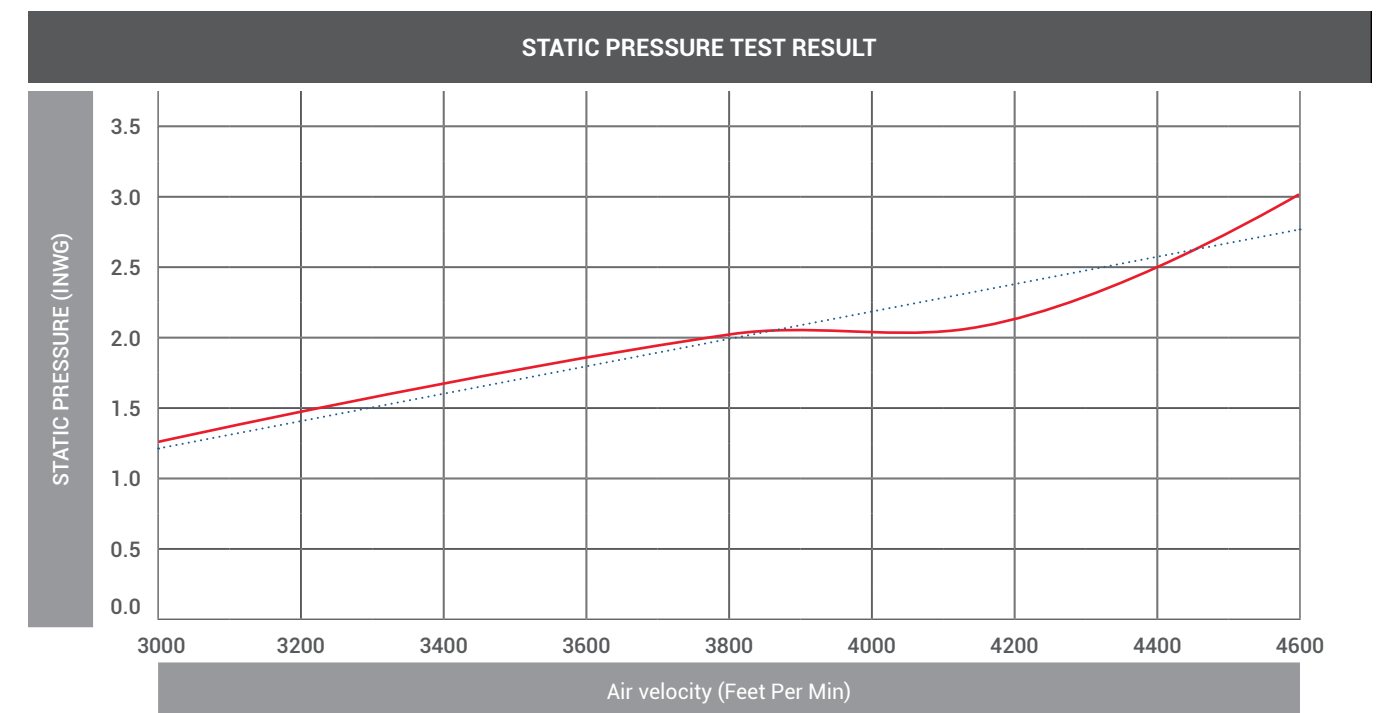



# CO<sup>2</sup> Fire Suppression System

## APPLICATIONS

The Raptor Breath™ CO<sup>2</sup> Fire Suppression System has the capability to provide protection from class A, B, and C fires in dust collecting vessels up to 900ft<sup>3</sup>.



## INSTALLATION INFORMATION

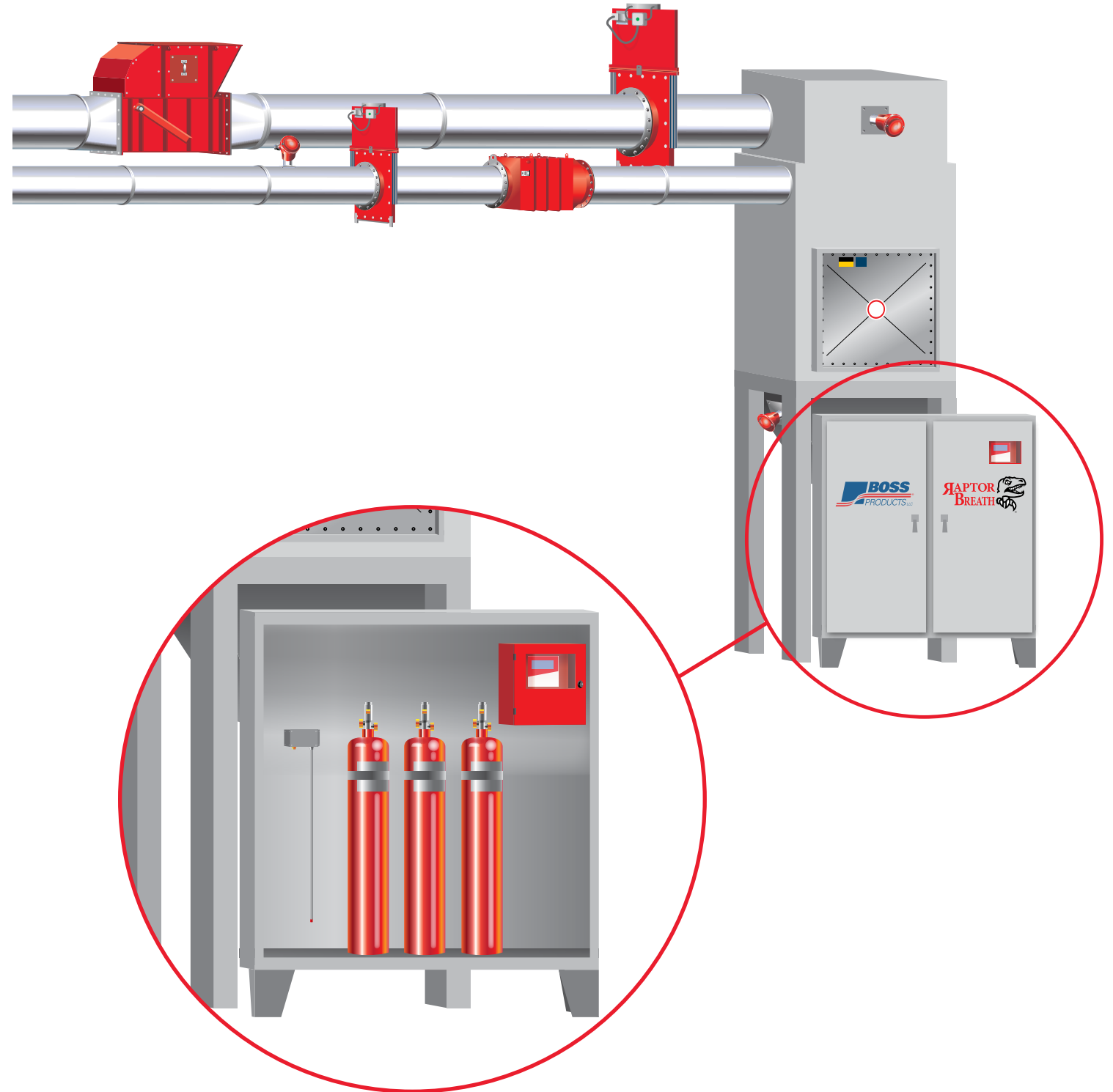

### STANDARD FEATURES

- The package comes fully assembled in an environmentally rated enclosure that is suitable for outdoor installations that only requires hoses to be mounted onto the dust collector for operation
- This system utilizes 50 lbs. CO<sup>2</sup> tanks to be activated by **thermal probes** which will detect a fire in the vessel, **firebreak shutters** on the inlet and outlet prevent any of the gas from escaping in a detect, isolate, and suppress process

### OPTIONAL FEATURES

- Standard sizes : 300ft<sup>3</sup>, 600ft<sup>3</sup>, 900ft<sup>3</sup>

### DIMENSIONS

- 300ft<sup>3</sup>: 72" H x 48" W x 20" D
- 600ft<sup>3</sup> to 900ft<sup>3</sup>: 72" H x 72" W x 20" D

### ACCESSORIES FOR CO<sup>2</sup> FIRE SUPPRESSION SYSTEM

- Distribution Hoses and connections
- EM-FBS (Fire Break Shutters)
- Audible and Visual Alarms
- RS-TP02 (Thermal Probes)



PRODUCT CODE: 56703

# Heavy Duty High Speed Abort Gate

PRODUCT CODE: 56703

## APPLICATIONS

The Raptor Gate™ Heavy Duty High Speed Abort Gate is an important part of any duct spark or leak detection system.

The Raptor Gate™ Heavy Duty High Speed Abort Gate can be located prior to the inlet of a dust collection system to prevent a flame or burning ember from entering the dust collection system. This method is used if your spark detection equipment is not adequate or not an option.

Fire, smoke, spark, or broken filter sensors can activate it in the event of a filter failure or fire.

The Raptor Gate™ Heavy Duty High Speed Abort Gate can be placed on the return air side of the dust collector to redirect contaminated air to safe location. It is just another way to keep personnel and dust collection equipment protected.

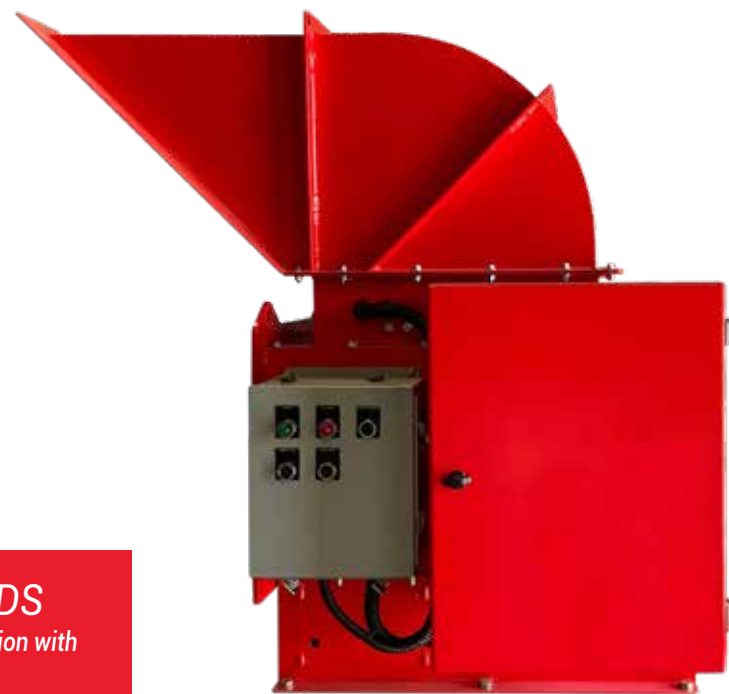

### CERTIFICATIONS & STANDARDS

NFPA 652 & 654 Compliant when used in conjunction with FM Approved Spark Detection System.



### STANDARD FEATURES

- Heavy duty and spring loaded with thicker walls and sturdier construction than the High Speed Abort Gate EM-HSAG02.
- Complete with hydraulic gate operation, indicator lights to monitor the system, manual test button, terminals to interlock with Raptor Spark detection system for activation, flanged inlet and outlet, and weather hood with bird screen.
- Available in sizes 4" to 60"

### OPTIONAL FEATURES

- 120V AC Control Panel.

## TECHNICAL INFORMATION

HEAVY DUTY HIGH SPEED ABORT GATE 18

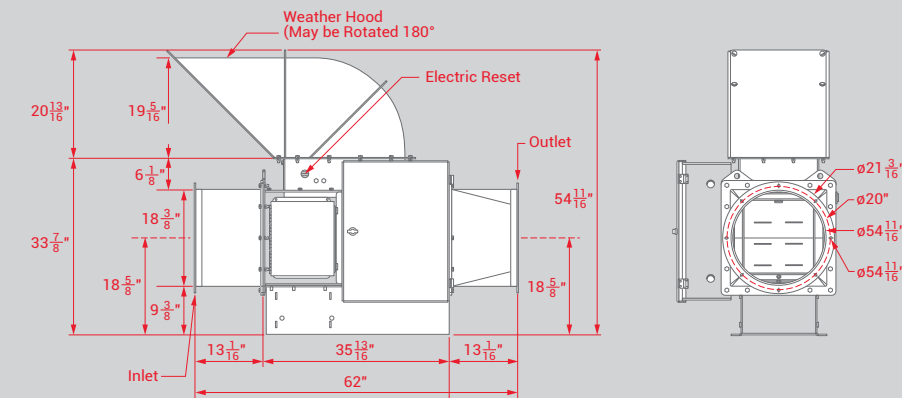

HEAVY DUTY HIGH SPEED ABORT GATE 56

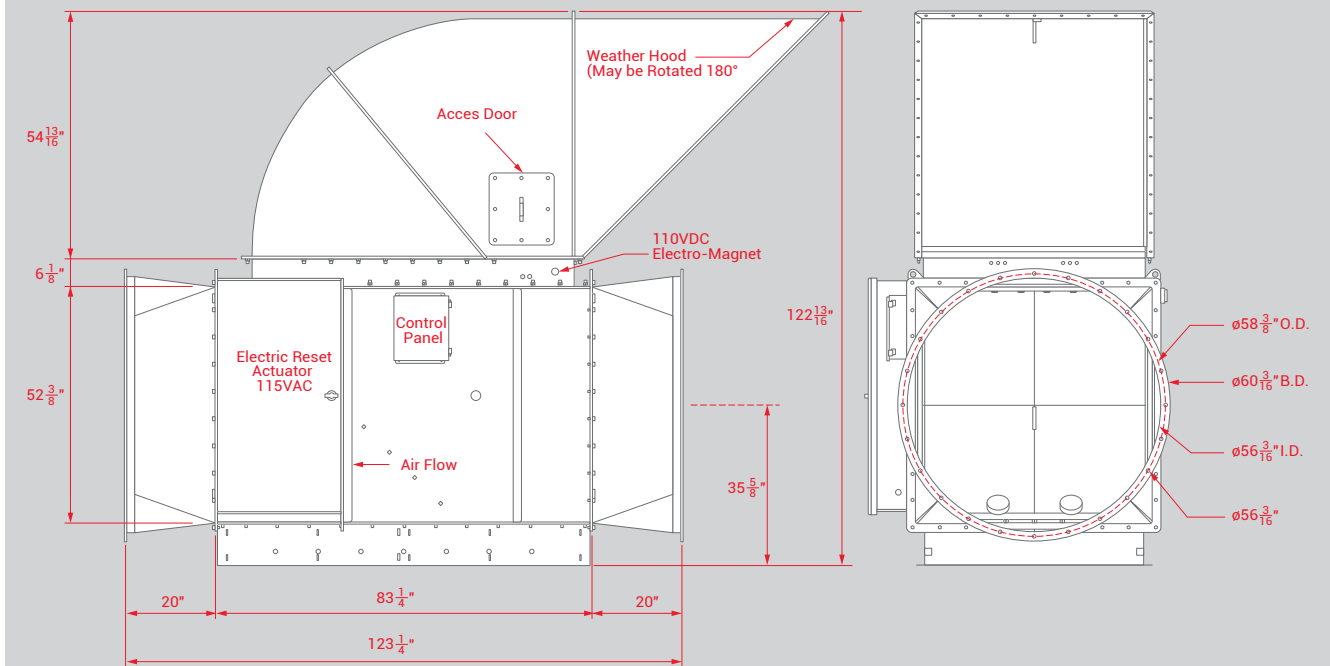



# High Speed Abort Gate EM-HSAG02

## APPLICATIONS

The High Speed Abort Gate EM-HSAG02 is specifically designed to be installed as a safety component when filtered air is returned to a building. NFPA requires a High Speed Abort Gate to be activated by an FM Approved Raptor Spark Detection and Extinguishing System. When the Raptor Spark™ Detection & Extinguishing Control Module detects a potential hazard, the return air is diverted to atmosphere, aborting potential fire from entering a workspace. This abort function can also be activated by the Dust Probe when dust particles are detected and/or the Thermal Probe.

The High Speed Abort Gate EM-HSAG02 is just one of the essential Fire & Explosion Protection system components provided by Boss Products. This component includes specific protection for Explosion Prevention, Fire Isolation & Diversion, specifically designed and engineered to be installed for the protection of workers, equipment, and buildings.



**CERTIFICATIONS & STANDARDS**  
 NFPA Compliant when used in conjunction with FM Approved Spark Detection System

**STANDARD FEATURES**

- 24V DC Control Panel with Status Lights
- Weather Hood
- Manual Reset Level
- Epoxy Powder coated safety red finish
- Flanged Inlet & Outlet
- NFPA Compliant with Spark Detection
- Electromagnetic Locking Mechanism

**OPTIONAL FEATURES**

- 110V AC Control Panel with Status Lights Pneumatic Reset EcoMAXX® Spark Detection & Extinguishing System

## TECHNICAL INFORMATION

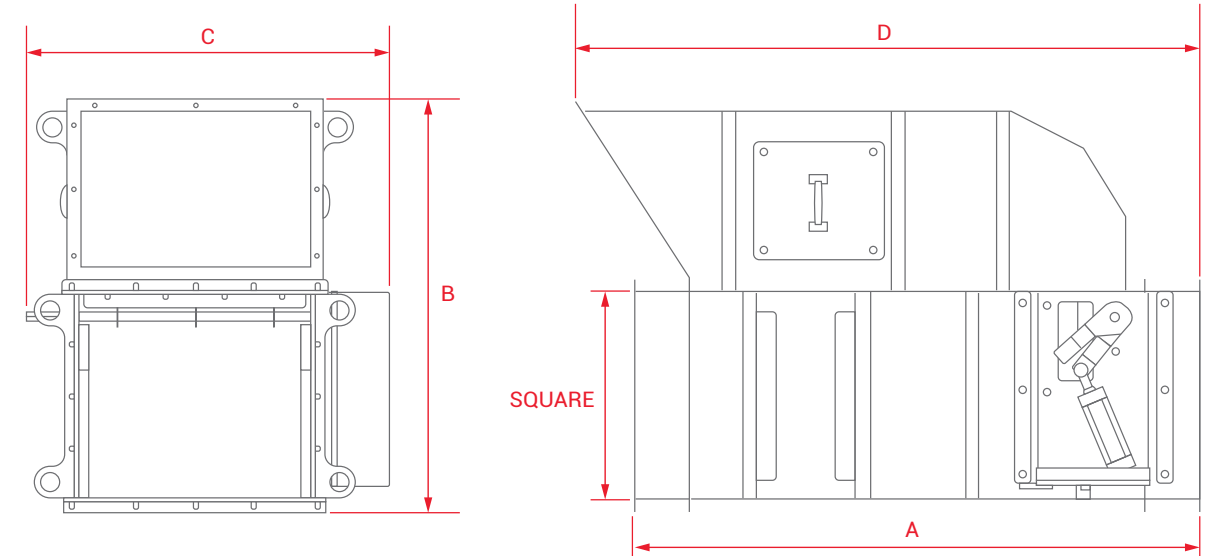

HIGH SPEED ABORT GATE SPECIFICATIONS							
ø [in] equivalent	Square [in]	Voltage	Reset	A [in]	B [in]	C [in]	D [in]
20	18x18	24 VDC	Manual Lever	41.0	25	12	40.50
24	22x22	24 VDC	Manual Lever	55.0	44	22	59.19
36	32x32	24 VDC	Manual Lever	77.5	63	32	87.44
44	40x40	24 VDC	Manual Lever	97.5	78	40	111.50
54	48x48	24 VDC	Manual Lever	115.5	92	48	132.94
60	54x54	24 VDC	Manual Lever	115.5	104	54	136.44
68	60x60	24 VDC	Manual Lever	115.5	115	60	136.44



# FireBreak Shutter EM-FBS

## APPLICATIONS

The FireBreak Shutter EM-FBS is engineered to isolate fires and fire hazards in process ventilation and dust collecting applications. The FireBreak Shutter is installed in multiple applications ranging from wood dust, metal dust, oil mist and/or any other process that has a fire hazard. Preventative (active) and reactive (passive) solutions are available.

## AVAILABLE MODELS

- EM-FBS00G – Gravity closure with manual reset
- EM-FBS00F – Gravity closure with manual reset. Fusible link activation.
- EM-FBS00M – Gravity closure using magnetic release with a pneumatic reset.
- EM-FBS00P & EM-FBS00PH – Pneumatic closure & reset, designed for vertical and horizontal positions.

## COMMON APPLICATIONS :

- Secondary protection in a Spark Detection and Extinguishing System
- Detect and isolation systems without suppression
- Dust collector/vessel isolation when used with a Fire Suppression System
- Production area/work zone isolation for high-risk processes



### STANDARD FEATURES

- 4 models/styles available from sizes 8" to 48" diameter
- Heavy-duty welded steel construction
- Flanged inlet and outlet with co-flanges
- Self-cleaning design
- Integral gasketing for positive seal
- Epoxy powder coated safety red finish
- ATEX certified\*

\* Model FBS-00M is provided as non-ATEX CE listed standard. ATEX version is available upon request.

### OPTIONAL FEATURES

- Thermal Probes for rapid temperature rise activation
- Microswitch for system shut down
- Compressed air reservoir tank
- Fire Suppression System
- Spark Detection and Extinguishing System

## CERTIFICATIONS & STANDARDS

EN 15650  
EN 1366-2  
EN 13501-3



## DIMENSIONS

* MANUAL RESET EM-FBS00G & EM-FBS00F *					
	A	B	C	weight lbs	
Ø 8"	30"	14"	21"	24	
Ø 10"	34"	16"	24"	30	
Ø 12"	38"	18"	27"	38	
Ø 14"	42"	20"	30"	44	
Ø 16"	46"	22"	33"	50	
Ø 18"	50"	24"	36"	60	
Ø 20"	54"	26"	39"	68	
Ø 22"	58"	28"	42"	80	
Ø 24"	62"	30"	45"	90	
Ø 26"	66"	32"	48"	102	
Ø 28"	70"	34"	51"	112	
Ø 30"	73"	36"	54"	140	

NOTE: All EM-FBS (firebreak shutters) come with flanged ends & co-flanges.

\* Units in inches rounded to the closest whole number

* MAGNETIC & PNEUMATIC EM-FBS00M, EM-FBS00P & EM-FBS00PH					
	A	B	C	D	weight lbs
Ø 8"	37"	22"	13"	24"	48
Ø 10"	39"	24"	13"	29"	55
Ø 12"	41"	26"	13"	30"	60
Ø 14"	46"	28"	13"	35"	68
Ø 16"	48"	30"	13"	36"	75
Ø 18"	58"	32"	13"	44"	88
Ø 20"	60"	35"	13"	45"	95
Ø 22"	66"	37"	13"	50"	110
Ø 24"	68"	40"	13"	51"	130
Ø 26"	74"	42"	13"	56"	150
Ø 28"	76"	44"	13"	57"	180
Ø **30"	82"	46"	13"	62"	205
Ø 32"	87"	47"	21"	64"	230
Ø 34"	93"	49"	21"	69"	255
Ø 36"	95"	51"	21"	70"	285
Ø 38"	101"	53"	21"	75"	305
Ø 40"	103"	56"	21"	76"	320
Ø 42"	109"	58"	21"	80"	345
Ø 44"	111"	60"	21"	81"	370
Ø 46"	117"	62"	21"	86"	395
Ø 48"	119"	64"	21"	87"	420

NOTE: \*\* EM-FBS00M magnetic model available to 30" diameter.

\* Units in inches rounded to the closest whole number

### Manual Reset

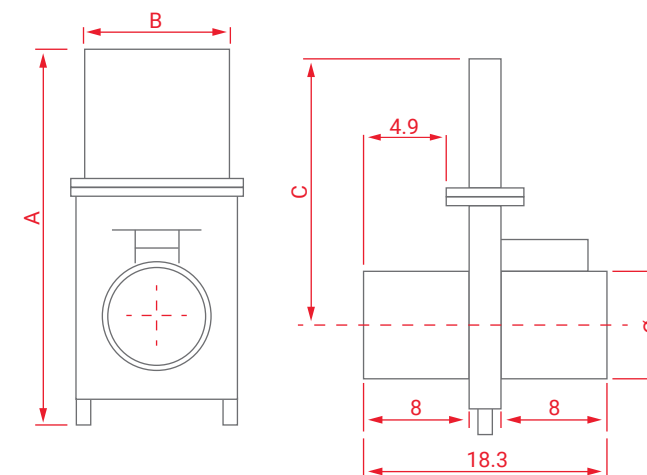

### Magnetic & Pneumatic

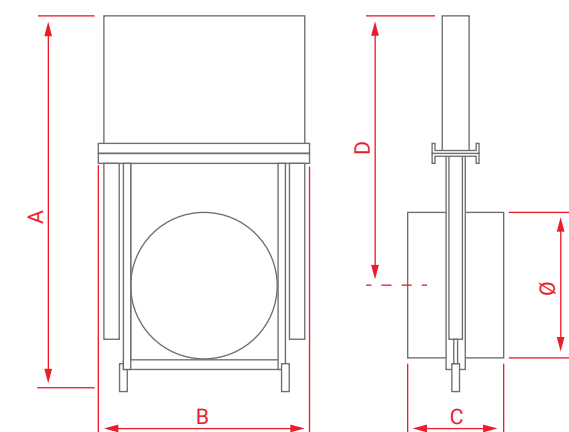



**EB-BDHD**  
ECOBOSS® Heavy duty barometric dampers



**EB-ABG**  
ECOBOSS® Automatic blast gates

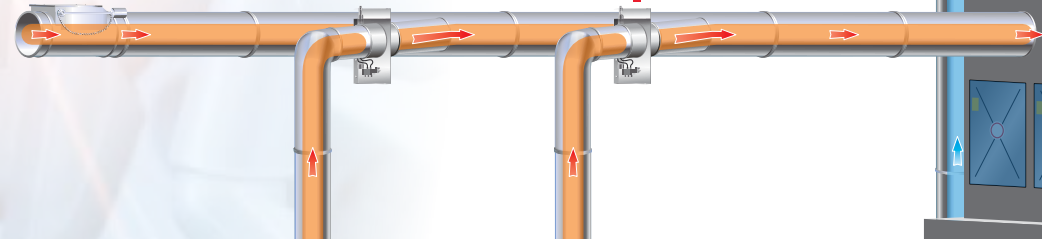

**EB-PBU**  
ECOBOSS® Power box ultimate

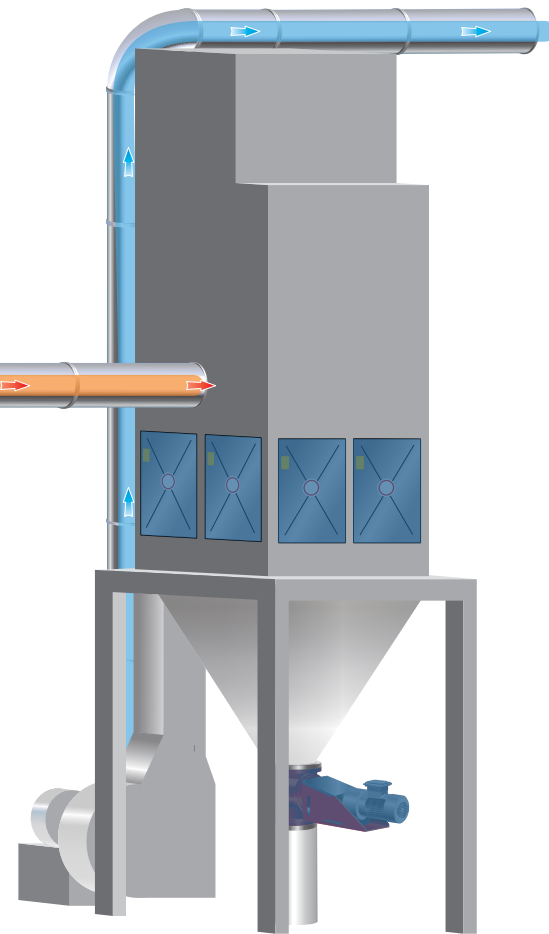

**EB-SVD**  
ECOBOSS® Stand alone variable speed drive

**M**odern manufacturing requires reliable and energy efficient automation solutions to be competitive in today's Global Marketplace. The **EcoBOSS®** product line of control and automation solutions has evolved over decades of experience in the filtration and process ventilation industry. **EcoBOSS®** combines **Industrial Safety Solutions** and **Energy Conservation Technology** into an advanced package that is ready to take industry well into the 21<sup>st</sup> century.

**Boss Products** operates its own in-house **UL 508A/UL698A & CVL Certified** electronics manufacturing facility. All **Boss Products** operations are **ISO 9001:2015 Certified**. Operations include electronics manufacturing of **EcoMAXX®** standard and specialty control panels, custom automation control panels and contract **OEM** controls manufacturing.

# Energy management control systems for industrial dust collection & ventilation

## APPLICATIONS

How EcoBOSS® can work for you :

EcoBOSS® Energy Management Control Systems deliver up to 80% reduction in kW consumption for typical industrial ventilation systems.

Boss Products engineers have spent years of research & testing to verify that the key to significant energy savings is to **regulate fan performance capacity to deliver the suction volume based on spindle run time.**

Typical industrial ventilation systems are designed to operate at full capacity. Extensive observation and case studies have shown that **actual spindle run time** rarely approaches 50% of full capacity during 90% of an average monthly production cycle !

EcoBOSS® Energy Management Control Systems have been designed to take full advantage of the Fan Affinity Law which clearly illustrates how an EcoBOSS® installation **will work for you.**

Advanced technology, systems engineering and modern components have been combined to create the EcoBOSS® Energy Management Controls. Three levels of EcoBOSS® controls have been developed & field tested to optimize the function of industrial ventilation control applications.

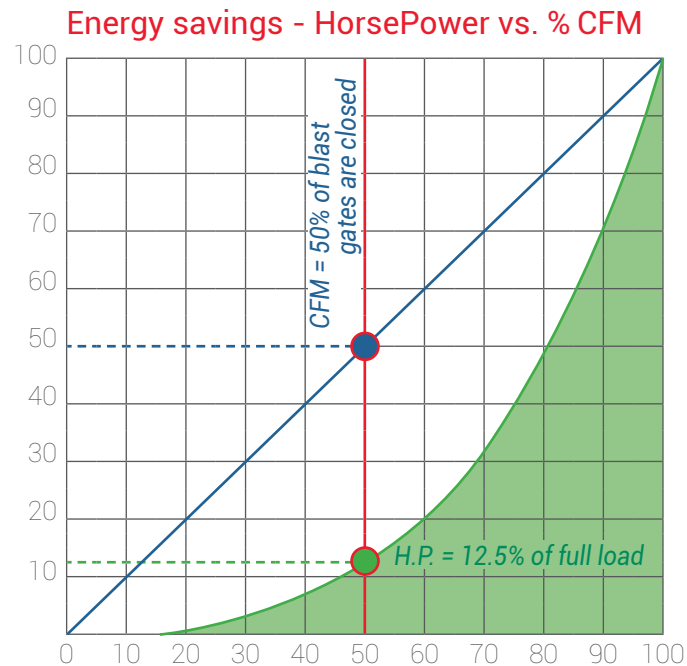

Air volume (CFM 50%)  
Power (H.P. %)

When a fan's airflow is reduced by 50% the kW consumption is reduced to 12.5% of full load.

## CERTIFICATIONS & STANDARDS



PRODUCT CODE: 55010

### ECOBOSS® LOOP BOX - EB-LB

Regulates fan speed dependent on varying filter pressure and resistance conditions to deliver optimum CFM. Remote start capable and designed to reduce energy consumption based on equipment utilization and spindle run time demand.



PRODUCT CODE: 55020

### ECOBOSS® POWER BOX - EB-PB

Regulates fan speed dependent on varying filter pressure and resistance conditions to deliver optimum CFM. Integrated logic controller sequencing auxiliary motors and operates automatic gates based on real time equipment utilization (spindle run time) through a simple integrated network system. Remote start capable and designed to reduce energy consumption based on equipment utilization and spindle run time demand.



PRODUCT CODE: 55030

### ECOBOSS® POWER BOX ULTIMATE - EB-PBU

Advanced technology Energy Saving Control System with external color touch screen programming for operation interface and expanded system capacity for larger systems. It regulates fan speed dependent on varying filter pressure and resistance conditions to deliver optimum CFM. A powerful logic controller operates automatic gates based on real time equipment utilization (spindle run time) through a simple integrated network and can sequence control of discharge valves, transfer fans, dirty filter alarms, fire extinguishing and/or suppression, explosion isolation, clean air abort return and variable pulse filter cleaning systems.



PRODUCT CODE: 55040

### ECOBOSS® STAND-ALONE VARIABLE SPEED DRIVE - EB-SVD

Critical component for all EcoBOSS® energy saving control systems. It drives the primary fan motor speed based on constant communication and feedback from an EcoBOSS® control panel for the most efficient operation. Proven technology and programming ensures optimum fan performance based on real time production conditions and safety requirements.



PRODUCT CODE: 55001

### ECOBOSS® POWER SUPPLY PANELS - EB-MPK

Stand-alone solution to power Automatic Blast Gate and sensor. It automatically starts and stops the exhaust fan. Models available with adjustable delay timer and manual override.







## OEM Control Panels EB-OEM

**Boss Products** owns and operates a fully staffed and state-of-the-art electrical control panel manufacturing center. We are a fully accredited **UL 508A** and **UL 698A** Panel Shop distributing to the USA and Canada Markets.

In addition to producing our own control panels, we provide quality control panel solutions for our **OEM**

**customers**, solution providers, integrators, and other specialty groups for various industries. We specialize in design, manufacturing, support services and always offer competitive pricing for small or large projects.

### INDUSTRIAL VENTILATION AND DUST COLLECTION APPLICATIONS

The staff at **Boss Products** are experts in the field of industrial ventilation and dust collection. Many of our staff members have spent most of their careers working in this field. We understand the equipment, the

processes, and their unique challenges. We have the experience and application knowledge that makes us uniquely qualified to ensure your system controls are operating effectively and trouble-free.



copyright 2020 Boss Products, LLC

**CERTIFICATIONS & STANDARDS**

### PRODUCTION CAPABILITIES

- Build to design or design and build
- Control panel manufacturing and listing
- Testing and quality control
- Control panel repair, maintenance and modifications
- Engineering and design
- CAD files and prints
- Application consulting
- Relay logic, AC & DC
- Drives, motor starters, PLC, HMI and PC based systems
- Custom programming
- Technical support, training, and commissioning services
- Private labeling

### PRODUCTION SOLUTIONS

- Motor starter panels with integrated filter cleaning controls, automatic startup/shutdown sequencing of auxiliary devices
- NFPA compliance interlocks for combustible dust producing machinery.
- Compliant interlocks of multiple ambient air cleaner and/or centralized push pull collector motors to work in tandem
- Filter, velocity and pressure monitoring systems with data logging, alarm and messaging
- Closed loop trailer loading systems with automatic switching, alarm, and messaging
- Vehicle exhaust control panels with or without damper control and automatic fan activation
- Automatic arc sensing in welding processes for damper and fan motor control
- Many Many MORE!

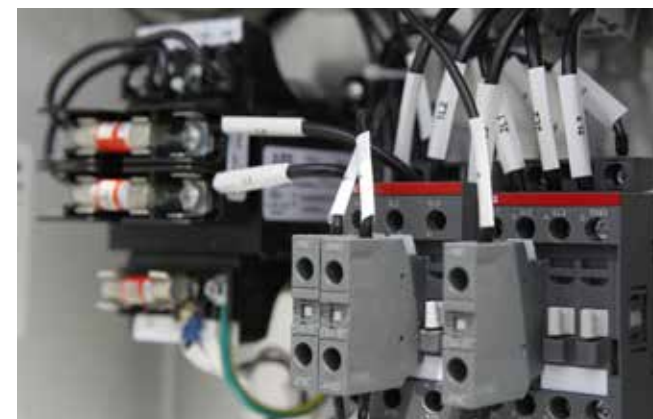

copyright 2021 Boss Products, LLC



# Automatic Blast Gates EB-ABG

PRODUCT CODE: 55101

## APPLICATIONS

EcoBOSS® 100% Positive Seal Pneumatic Blast Gates are an essential energy saving component for all dust collection and air handling systems.

## DIMENSIONS

HEAVY DUTY AUTOMATIC BLAST GATES * EB-ABG00HD Size 14" - 32"							
Ø	A	A1	B	B1	H	C	# of Cylinders
14"	18	24	31	44	11	47	2
16"	20	25	31	46	11	49	2
18"	22	27	35	52	11	55	2
20"	24	30	35	54	11	57	2
22"	26	32	39	60	11	65	2
24"	28	34	39	62	11	65	2
26"	30	36	43	68	11	71	2
28"	32	38	43	70	11	73	2
30"	34	41	47	76	11	79	2
32"	36	43	47	78	11	81	2

\* Units in inches rounded to the closest whole number

AUTOMATIC BLAST GATES EB-ABG00 Sizes 4" - 12" *				
Ø	A	B	C	# of Cylinders
4"	7	11	16	1
5"	8	13	18	1
6"	9	15	21	1
8"	11	19	28	2
10"	13	23	33	2
12"	15	27	39	2

\* Units in inches rounded to the closest whole number

AUTOMATIC BLAST GATES EB-ABG00 Sizes 4" - 12"

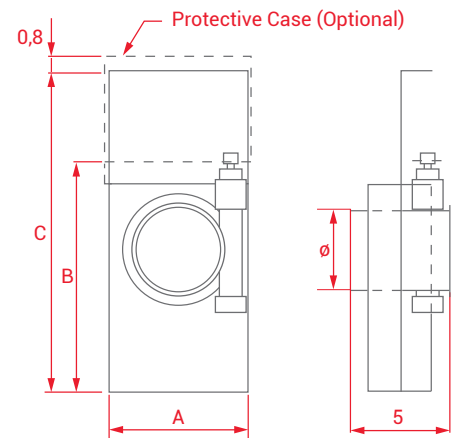
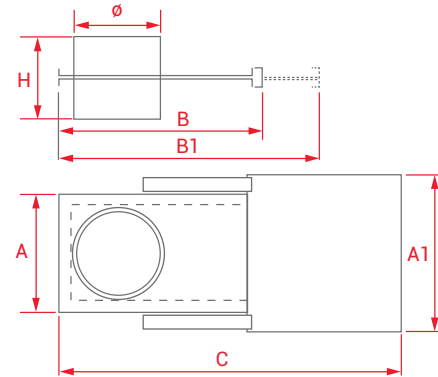

## STANDARD FEATURES

- Heavy duty galvanized steel construction
- 24 VDC, 24 VAC or 110 VAC solenoid with LED indicator light
- Sizes 4" - 12" come standard with 90° flared ends for use with optional quick connection clamps and adapters
- Sizes 14" - 32" HD Gates come standard with flanged ends and co-flanges
- Polyethylene gasket for 100% positive seal on sizes 4"-12". Larger HD Gates utilize brass for ease of movement and feature rubber and felt gasket. All HD Gates are self cleaning

## OPTIONAL FEATURES

- EB-ABG-PC00 – Protective Case Sizes 4" - 12", standard on all larger HD Gates
- EB-MPK – Transformer panels with plug for use with low voltage sensors on stand-alone applications
- Pneumatic Distribution & Wiring Solutions
- Comprehensive EcoBOSS® Energy Saving Control Systems



# Heavy Duty Barometric Dampers EB-BDHD

PRODUCT CODE: 55601

## APPLICATIONS

EcoBOSS® Heavy Duty Barometric Dampers are designed to automatically bleed in air to avoid fan instability and maintain suitable conveying velocities in duct lines.

## DIMENSIONS

HEAVY DUTY BAROMETRIC DAMPERS	
Ø	Length
6"	17"
8"	19"
10"	21"
12"	23"
14"	25"
16"	27"
18"	29"
20"	31"
22"	33"
24"	35"

\* Units in inches rounded to the closest whole number

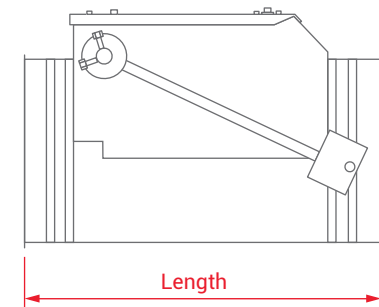

## STANDARD FEATURES

- Heavy duty galvanized steel construction
- Heavy duty adjustable counterweight with safety chain
- Removable inspection door
- Sizes 6" through 18" : 90° flared ends for use with optional quick connection clamps and adaptors
- Sizes 20" and larger : Flanged ends with co-flanges

## OPTIONAL FEATURES

- Pneumatic model with velocity sensor
- Sainless steel AISI 304 and 316 construction

# M-Jet Grain Elevator Hazard Monitoring

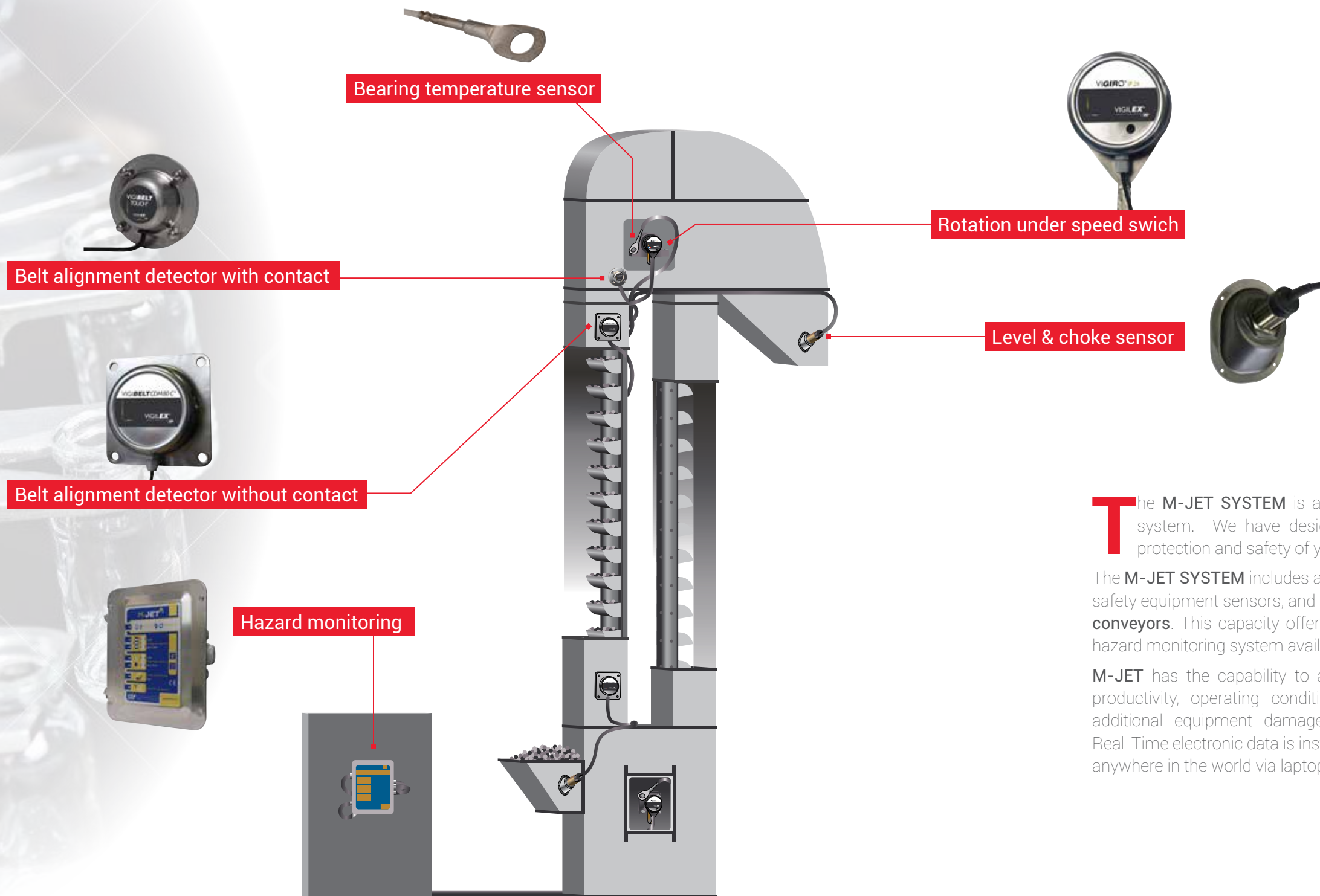

The **M-JET SYSTEM** is a modern and dynamic safety monitoring system. We have designed a complete system to ensure the protection and safety of your personnel and equipment.

The **M-JET SYSTEM** includes a complete range of hazard monitoring and safety equipment sensors, and is designed to protect up to **120 individual conveyors**. This capacity offers the most economical conveyor system hazard monitoring system available.

**M-JET** has the capability to accurately monitor, manage and analyze productivity, operating conditions and hot-spots that could lead to additional equipment damage, costly repairs and explosion hazard. Real-Time electronic data is instantly **available 24/7** and can be accessed anywhere in the world via laptop, tablet or mobile phone.

# M-JET SYSTEMS

## The world's most advanced hazard monitoring system

### THE SMART WAY TO MANAGE YOUR SAFETY SYSTEM

The M-JET Safety Monitoring System ensures complete control and real time data that is necessary to avoid unneeded maintenance and explosion hazard. **Data Reports** include dangers associated with speed control, misalignment, level & choke control, bearing and motor temperatures. M-JET SYSTEMS is specifically designed as an early warning system to alert facilities to potential sources of explosion ignition

Think Safety Smart. Think M-Jet to protect your employees and your facility.



### THE SMART WAY TO MANAGE YOUR CONVEYOR SYSTEMS :

- Under speed due to belt slip on the pulley. To check comparing with the nominal speed.
- Bearing temperature using sensor PT100 or NTC.
- Belt misalignment using sensors with or without contact.
- Material jam in conveyor entry or exit using capacitive sensor.
- Chain elongation measured by inductive sensor and targets.
- Motor power measurement with specific electrical consumption.
- Shaft position measured by sensor 4-20mA.

### THE OPERATING CONTROL OF THE SYSTEM IS ACHIEVED BY OUTPUT RELAYS :

- Directly on the power relay of the motor.
- By the global PLC of the facilities.

### VERIFYING THE CONVEYOR OPERATION CAN BE ACHIEVED BY :

- On computer screen by internal website (directly with laptop or by Network LAN).
- By message on the email box (events and maintenance operation plan).

### M-JET SYSTEMS ELECTRONIC CONNECTIVITY VIA INTERNET OR FACILITY NETWORK :

- Remote monitoring up to 120 conveyors from the same display unit
- Unified viewing of data in real time
- Graphic display of historical data
- Alarm notification by sending email
- Viewing of alarms
- Support tools to manage preventive maintenance

Type	Name	Place	Status	Speed	Cpt/Day	Cpt/General
EL02	Place 2	Alarm	-	8h	1850h	
TB01	Place 1	Pre-Alarm	1,8 m/s	7h	1575h	
EL01	Place 1	Ok	2,4 m/s	5h	1125h	
EL03	Place 3	Ok	2,8 m/s	3h	925h	
EL04	Place 4	Inactif	-	-	125h	

**Elevator EL02 — Place STIF USA — 25 march 2018 15h31** Status: Alarm

Dashboard | Temperature graph | Alarm graph | Alarm analysis | Maintenance | Param. M.JET.COM

UNDER SPEED		TEMPERATURE	
Speed	000 rpm	T <sup>m</sup> Max	80°C
Under speed	10 %	No.4	65°C
No.2	-	No.3	68°C
No.1	Ok	No.2	58°C
		No.1	56°C
		T <sup>m</sup> Max motor	90°C
		No.2	73°C
		No.1	Ok

**ELEVATOR STOPPED**  
EL02 Alarm Misalignment No.2

Access to graphics



jetmonitoringsystem.com  
is available on all your mobile devices

### HISTORIC DATA ANALYSIS : ONLY BY COMPUTER, DIRECTLY WITH LAPTOP OR BY NETWORK LAN

- History of defects: M-JET SYSTEMS can save 10,000 events.
- History of setting modification: Save the 10,000 last setting modifications.
- History of daily running time of the equipment :
  - M-JET SYSTEMS saves production time during the last 4,000 days of use.
  - M-JET SYSTEMS records temperatures 24 times per day during the last 365 days of use.
- All the history can be downloaded in csv format.

Run time

Temperatures

Number of alarms

Ratio of alarms by type

# M-JET SYSTEMS

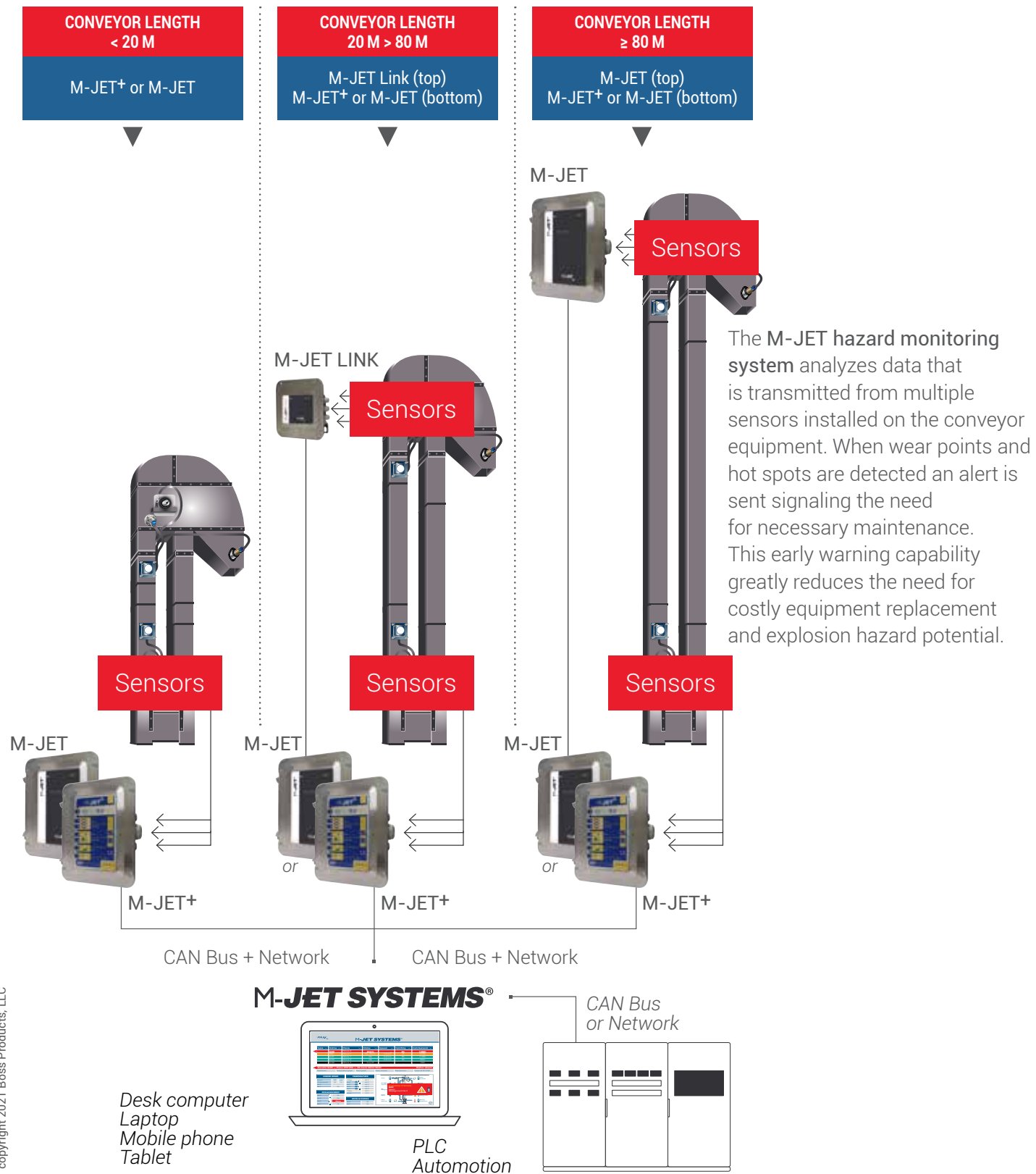

copyright 2021 Boss Products, LLC

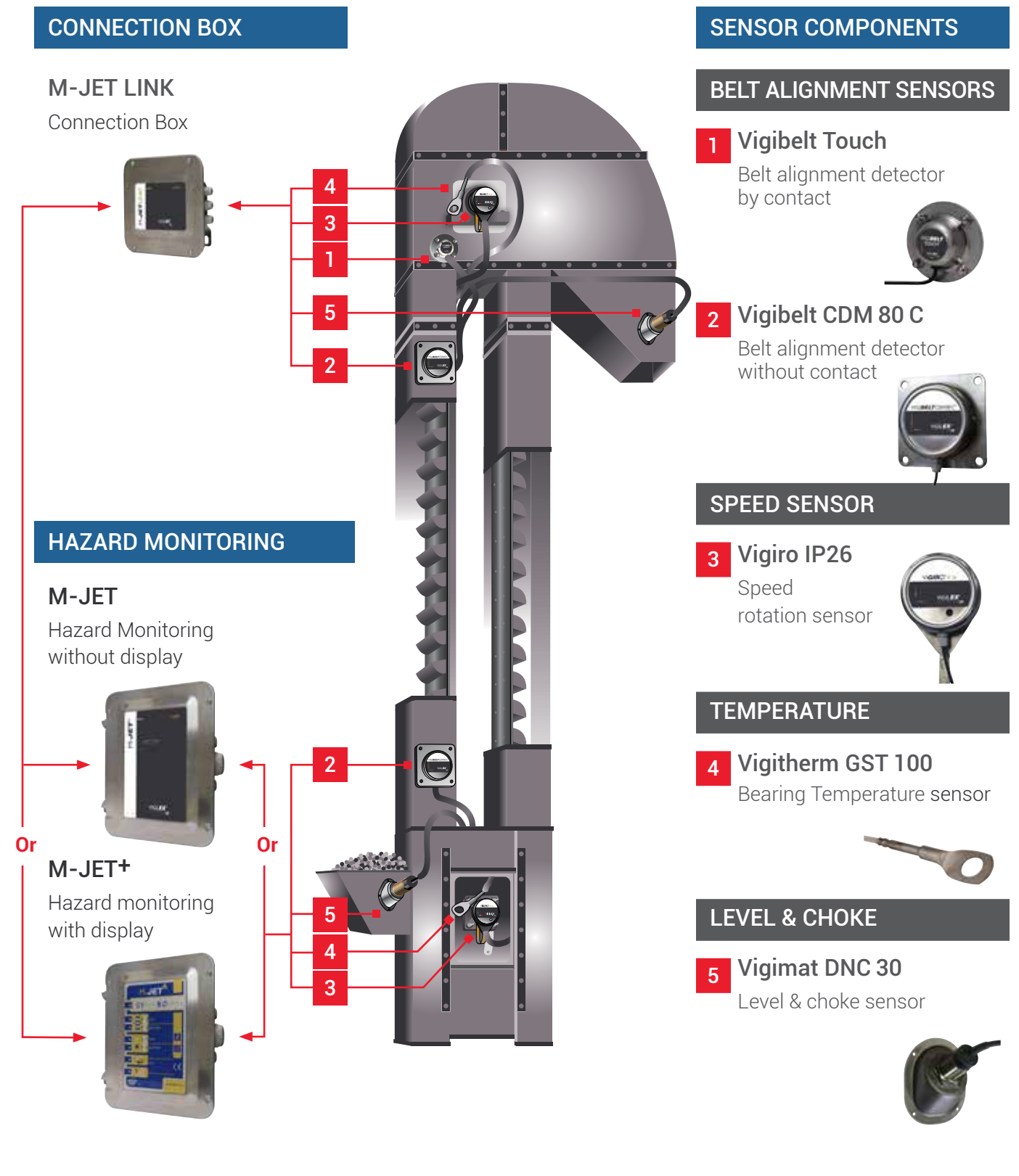

copyright 2021 Boss Products, LLC



Transitioning the World to a Safer Working Environment



ISO 9001 : 2015 Certified Company, Certificate #12373

# RAPTOR Series™



6729 GUADA COMA DR. - SCHERTZ, TX 78154 -USA - Main # 210-664-4200

[www.bossproductsamerica.com](http://www.bossproductsamerica.com)    [info@bossproductsamerica.com](mailto:info@bossproductsamerica.com)